

es-fit LS-fit エスフィット/エルエスフィット

STAINLESS STEEL FITTINGS es-fit / LS-fit

特長 Features

- Easy Fit機構(ナット・スリーブ一体化)採用で作業効率向上。
The adoption of the Easy Fit mechanism improves the work efficiency.
- アオイ独自のスリーブ採用により、配管時のチューブの捻じれを解消。
The adoption of the AOI's original sleeve eliminates the tube torsion.
- 繰り返しの使用にもスリーブ交換不要。
There is no need to change the sleeve even in use of repetition.
- 禁油処理をおこなっています。
Degreasing processed.
- 本体、ナット、スリーブ材質はSUS316のため優れた耐蝕性。
The material of main body, nut, and sleeve is SUS316, that has the outstanding corrosion resistance.
- 平滑な本体内径面。
Smooth surface of inner diameter of main body.
- サイズバリエーションが豊富なため各種チューブにフィット。
The extensive variations of size allow to fit various tubes.
- 流量特性に優れた継手。
Excellent flow characteristics.

仕様 Specifications

使用流体 Fluid used	空気、水、薬品等 Air, Water, Chemicals etc.
最高使用圧力 Max. Working pressure	チューブの最高使用圧力に準じます。 Conforming to the maximum working pressure of the tube.
使用温度※ Working temperature	-65°C~260°C(空気) 0°C~100°C(水) -65°C~260°C for air. 0°C~100°C for water.
負圧 Negative pressure	0.1Torr(-101.3kPa)

※Oリング及びパッキンを使用している製品についてはお問い合わせください。
Please inquire us for products that use O rings and packing.

適用チューブ Applicable Tube

エコフレックスチューブ ecos, ecoh, ecoh(wr)	eco-flex tubes
ふっ素樹脂チューブ(FE) 但し、φ4mmサイズはFE-04-2.5のみ φ3.2mm×φ1.6~φ4mm×φ2mmの サイズは受注生産品で対応可能	Fluorine Resin Tubes We supply φ4mm size of this series only for FE-04-2.5. We can supply φ3.2mm×φ1.6mm~ φ4mm×φ2mm of tubes as make-to-order models.
その他 各種チューブ (適用チューブサイズ表参照)	Others Various Tubes (Please refer to the applicable tube size table.)

※ナイロンチューブご使用の際はお問い合わせください。
Please inquire of us about use of nylon tubes.

構造断面図 Internal Structure

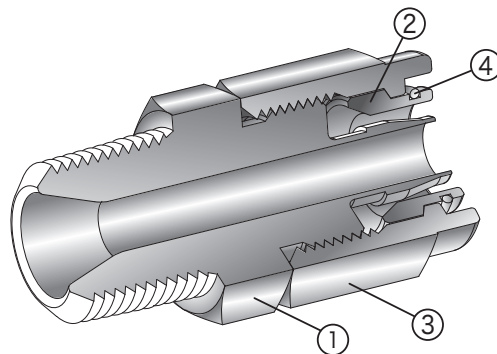

主要部品材質 Main Part Materials

名称 Part Name	材質 Material	
	es-fit	LS-fit
① 本体 Body	SUS316, SUS316L	
② スリーブ Sleeve	SUS316	C3604BD (無電解Niメッキ)
③ ナット Nut	SUS316	C3604BD (無電解Niメッキ)
④ ストップリング Back Up Ring	SUS304	

① 大流量化を実現
Achievement of making the flow rate larger.

② 配管時のチューブねじれを解消
Eliminating of the tube torsion problems at the time of plumbing.

③ スリーブとの一体化構造により取付け、取外しの作業時間短縮
Unification structure allows the quick connection/disconnection.

④ スリーブの紛失、取付け方向の間違えによるトラブル解消
Preventing the loss of the sleeve.
Solving the troubles caused by the mistake of the installation direction.

■ 適用チューブサイズ Applicable Tube Size

(unit:mm)

チューブ外径 Tube O.D.	外径 × 内径 O.D.×I.D.
φ4	φ4 × φ2.5
φ6	φ6 × φ4
φ8	φ8 × φ5
	φ8 × φ6
φ10	φ10 × φ6.5
	φ10 × φ7.5
	φ10 × φ8
φ12	φ12 × φ8
	φ12 × φ9
	φ12 × φ10

記載インチサイズ Stated inch size	チューブ 外径 × 内径 Tube O.D × I.D
1/8	φ3.18 × φ2.25
3/16	φ4.76 × φ3.48
1/4	φ6.35 × φ4.57
5/16	φ7.94 × φ5.90
3/8	φ9.53 × φ6.99
1/2	φ12.70 × φ9.56

■ 型番表示方法 How to Designate



es-fit,LS-fit シリーズ記号
es-fit,LS-fit Series Name

es	es-fit
ES	
LS	LS-fit

機種別
Part No. of Standard Type

IL	エルボユニオン	Male Elbow
IT	T型ユニオン	T Type Connector
H	ハーフユニオン	Male Connector
L	エルボユニオン	Male Elbow
S	ストレートユニオン	Equal Union
E	隔壁ユニオン	Bulkhead Union
EH	隔壁ハーフユニオン	Bulkhead Male Connector
EP	隔壁メスユニオン	Bulkhead Female Connector
F	両口エルボユニオン	Union Elbow
PW	メスユニオン	Female Connector
D	D型ユニオン	D Type Connector
C	C型ユニオン	C Type Connector
T	T型ユニオン	T Type Union
LD	エルユニオン 方向決めタイプ	L Type Connector
LR	ターンエルボユニオン	Turn Elbow
RN	ニードルバルブ	Needle Valve
LL	ロングエルボユニオン	Long Male Elbow
40L	40° エルボユニオン	40° Male Elbow
HR	Rネジユニオン	R Screw Union
HRC	RCネジユニオン	RC Screw Union
ES	隔壁ネジユニオン	Bulkhead Screw Union
AL	L型ネジユニオン	L Type Screw Union
AD	D型ネジユニオン	D Type Screw Union
N	スリーブ一体ナット	Integral Sleeve Nut

適用チューブ外径×内径
Applicable Tube O.D × I.D

3216	φ3.2 × 1.6
0402	φ4 × 2
0425	φ4 × 2.5
0604	φ6 × 4
0805	φ8 × 5
0806	φ8 × 6
1065	φ10 × 6.5
1075	φ10 × 7.5
1008	φ10 × 8
1208	φ12 × 8
1209	φ12 × 9
1210	φ12 × 10
1613	φ16 × 13
1/8	1/8インチ
3/16	3/16インチ
1/4	1/4インチ
5/16	5/16インチ
3/8	3/8インチ
1/2	1/2インチ
2SG	G(PF)1/4 ねじサイズ Screw size
3SG	G(PF)3/8 ねじサイズ Screw size

配管 ねじサイズ
Piping Screw size

0	取付ねじ無し Not Set Screw
1	R(Rc) 1/8
	G(PF) 1/4
2	R(Rc) 1/4
	G(PF) 1/4
3	R(Rc) 3/8
	G(PF) 3/8
4	R(Rc) 1/2
	G(PF) 1/2
2GNT	G(PF) 1/4
3GNT	G(PF) 3/8
S2R	G(PF) 1/4 スイベルナット swivel nut
S3R	G(PF) 3/8 スイベルナット swivel nut

オプション
Option

無記号 (None)	標準スリーブ Standard Sleeve
SL	ロングスリーブ Long Sleeve

パッキン材質
Packing material

無記号 (None)	ナイロン(PA6) Nylon(PA6)
F	ふっ素(PTFE) Fluorine(PTFE)

※ガードワイヤー付きの場合は、ねじサイズの末尾に「GW」を記載
For models with a guard wire, add "GW" at the end of the piping screw size.

■ ロングスリーブタイプ寸法について About long sleeve type dimensions

下図のように長いスリーブの ロングスリーブタイプもご選択できます。

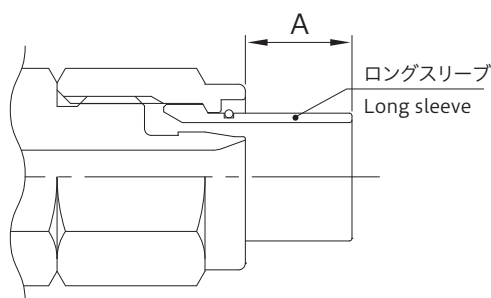

〈ロングスリーブタイプ構造断面図〉
Structural cross section for long sleeve type

ロングスリーブタイプ寸法 Long sleeve type dimensions			
適用チューブ Applicable Tube (ミリサイズ) (mm size)	A寸法 ASize	適用チューブ Applicable Tube (インチサイズ) (inch size)	A寸法 ASize
φ4	4mm	1/8	4mm
φ6	6mm	3/16	4mm
φ8	8mm	1/4	6mm
φ10	10mm	5/16	8mm
φ12	10mm	3/8	10mm
		1/2	10mm

■ 取付手順 Method of Connecting for Tube

1. チューブを直角に切断してください。
Please cut the tube perpendicularly.
2. 継手はセットされた状態で納品されます。
The fitting is delivered in a state whose nut was built into the main body.
3. 本体とナットを分離させてください。
Please separate the main body and nut.
4. 継手本体Rねじ部を機器に工具を使用して締付けてください。
Please tighten the R-screw of the main body of the fitting to the equipment with a tool.
5. ナットを通したチューブを本体突起部の根本まで挿入してください。
Please insert the tube through a nut to the root of the protrusion of the main body.
6. スパナにてナットを本体に突き当たるまで締め込んでください。
Please tighten a nut with spanner until it hits the main body.
7. 再取り付けの際はチューブの先端を直角に切断してください。
When reconnecting, please cut the tube-tip perpendicularly again.

■ 推奨締付トルク Recommended Tightening Torque

ねじサイズ Screw (JIS B0203)	締付トルク (N・m) Tightening torque (N・m)
R1/8	7~9
R1/4	12~14
R3/8	22~24
R1/2	28~30

※推奨締付トルクはお守りください。

目安としては手締めの後、スパナ等の工具にて2~3回転に相当します。

Please follow the recommended tightening torque.

As a standard, it is equivalent to 2-3 turns by tools, such as a spanner, after tightening by hand.

※es-fitはクリーン性が要求される分野での使用を考慮し、Rねじ部にはシーロック加工をしておりません。Rねじ部にはシールテープまたはシール剤等をご使用ください。

In consideration of use in the field where the clean characteristic is demanded, the fluorine resin coating is not processed to R-screw of the es-fit series. Please use the seal tape or seal adhesive for R-screw.

■ 特殊仕様 Special Specifications

使用流体・環境によりパッキン材質や使用潤滑剤、組立て・梱包環境等 対応致します。
対応可能な主な特殊仕様については「Z型番」として下記の様に設定しています。

Depending on the fluid/environment used, we will adapt the packing material, lubricant used, assembly/packaging environment, etc.

仕様 (Z型番) Specifications	内 容 Content						
	型番表示 model number	シール剤 Sealing material	Oリング O Ring	潤滑剤 Lubricant	洗 浄 Washing	組立環境 Assembly environment	梱包環境 Packing environment
クリーンルーム clean room	Z80	—	NBR	禁 油 No Oil	部品・製品 (クリーンルーム) Parts/Products (Clean room)	クリーンルーム Clean room	クリーンルーム Clean room

型番末尾に「-Z80」と記載してください。

上記以外の特殊仕様については、お問い合わせください。

禁油処理について：接液部に油脂類の残留がないように処理しております。

Please add “-Z80” at the end of the model number.

Please contact us for special specifications other than those listed above.

About degreasing : The wetted part is treated so that there is no residue of oils and fats.

ESIL (エルボユニオン)

Male Elbow

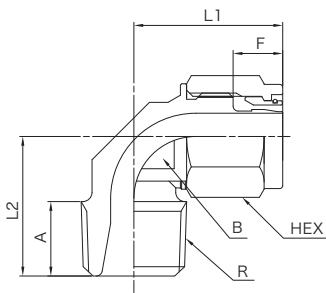

型番 Model No.	適用チューブ 外径×内径 Applicable tube O.D.×I.D.	R(PT)	L1	L2	A	F	最小穴径 Diameter of the min. hole	HEX	B
ESIL-0425-1	4×2.5	R1/8	17	17	9	6	1.9	10	12
ESIL-0425-2		R1/4		19	11				
ESIL-0604-1	6×4	R1/8	18.5	17	9	7	3.4	12	12
ESIL-0604-2		R1/4		19	11				
ESIL-0604-3		R3/8		20	12				
ESIL-0805-1	8×5	R1/8	21	18	9	7.5	4.4	14	14
ESIL-0805-2		R1/4		20	11				
ESIL-0805-3		R3/8		21	12				
ESIL-0806-1	8×6	R1/8	21	18	9	7.5	5.4	14	14
ESIL-0806-2		R1/4		20	11				
ESIL-0806-3		R3/8		21	12				
ESIL-1065-2	10×6.5	R1/4	24	21.5	11	8	5.9	17	17
ESIL-1065-3		R3/8		22.5	12				
ESIL-1065-4		R1/2		25.5	15				
ESIL-1075-2	10×7.5	R1/4	24	21.5	11	8	6.9	17	17
ESIL-1075-3		R3/8		22.5	12				
ESIL-1075-4		R1/2		25.5	15				
ESIL-1008-2	10×8	R1/4	24	21.5	11	8	7.4	17	17
ESIL-1008-3		R3/8		22.5	12				
ESIL-1008-4		R1/2		25.5	15				
ESIL-1208-2	12×8	R1/4	27	23	11	9.5	7.2	19	19
ESIL-1208-3		R3/8		24	12				
ESIL-1208-4		R1/2		27	15				
ESIL-1209-2	12×9	R1/4	27	23	11	9.5	7.9	19	19
ESIL-1209-3		R3/8		24	12				
ESIL-1209-4		R1/2		27	15				
ESIL-1210-2	12×10	R1/4	27	23	11	9.5	7.9	19	19
ESIL-1210-3		R3/8		24	12				
ESIL-1210-4		R1/2		27	15				

ESIT (T型ユニオン)

T Type Connector

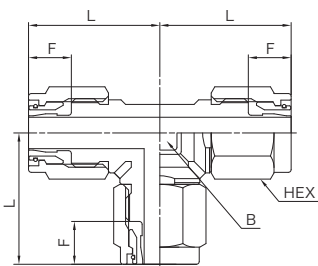

型番 Model No.	適用チューブ 外径×内径 Applicable tube O.D.×I.D.	L	F	最小穴径 Diameter of the min. hole	HEX	B
ESIT-0604-0	6×4	20.5	7	3.4	12	8

ステンレス製締付継手

黄銅製締付継手

PEEK製継手

ステンレス製
カップル

ステンレス製
チェックバルブ

ステンレス製
スピードコントローラー

ステンレス製
ニードルバルブ

ミニチュア
フィッティング

ワンタッチ継手

スピードコントローラー
AQバルブ

esh/ESH (ハーフユニオン)

Male Connector

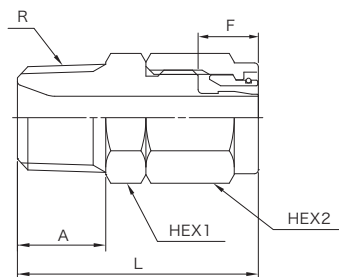

型番 Model No.	適用チューブ 外径×内径 Applicable tube O.D.×I.D.	R (PT)	L	A	F	最小穴径 Diameter of the min. hole	HEX1	HEX2
ESH-3216-1 ●	3.2×1.6	R1/8	24	9	6	1	10	10
ESH-0402-1 ●	4×2	R1/8	24	9	6	1.2	10	10
ESH-0402-2 ●		R1/4	26	11			14	
esh-0425-1	4×2.5	R1/8	24	9	6	1.9	10	10
esh-0425-2		R1/4	26	11			14	
esh-0604-1	6×4	R1/8	26	9	7	3.4	12	12
esh-0604-2		R1/4	28.5	11			14	
esh-0604-3		R3/8	30	12			17	
esh-0805-1	8×5	R1/8	28	9	7.5	4.4	14	14
esh-0805-2		R1/4	30	11			17	
esh-0805-3		R3/8	31	12			17	
esh-0806-1	8×6	R1/8	28	9	7.5	5.4	14	14
esh-0806-2		R1/4	30	11			17	
esh-0806-3		R3/8	31	12			17	
esh-1065-2	10×6.5	R1/4	32	11	8	5.9	17	17
esh-1065-3		R3/8	33	12			22	
esh-1065-4		R1/2	36	15			22	
esh-1075-2	10×7.5	R1/4	32	11	8	6.9	17	17
esh-1075-3		R3/8	33	12			22	
esh-1075-4		R1/2	36	15			22	
esh-1008-2	10×8	R1/4	32	11	8	7.4	17	17
esh-1008-3		R3/8	33	12			22	
esh-1008-4		R1/2	36	15			22	
esh-1208-2	12×8	R1/4	34	11	9.5	7.2	17	19
esh-1208-3		R3/8	35	12			22	
esh-1208-4		R1/2	38	15			22	
esh-1209-2	12×9	R1/4	34	11	9.5	7.9	17	19
esh-1209-3		R3/8	35	12			22	
esh-1209-4		R1/2	38	15			22	
esh-1210-2	12×10	R1/4	34	11	9.5	7.9	17	19
esh-1210-3		R3/8	35	12			22	
esh-1210-4		R1/2	38	15			22	
ESH-1613-3 ●	16×13	R3/8	38	12	10.5	11.9	22	22
ESH-1613-4 ●		R1/2	41	15			22	
ESH-3/16-1 ●	4.76×3.48	R1/8	24	9	6	2.8	10	10
ESH-3/16-2 ●		R1/4	26	11			14	
ESH-1/4-1 ●	6.35×4.57	R1/8	26	9	7	3.9	12	12
ESH-1/4-2 ●		R1/4	28.5	11			14	
ESH-5/16-1 ●	7.94×5.9	R1/8	28	9	7.5	5.4	14	14
ESH-5/16-2 ●		R1/4	30	11			17	
ESH-5/16-3 ●		R3/8	31	12			17	
ESH-3/8-2 ●	9.53×6.99	R1/4	32	11	8	6.3	17	17
ESH-3/8-3 ●		R3/8	33	12			17	
ESH-1/2-2 ●	12.7×9.56	R1/4	34	11	9.5	7.9	19	21
ESH-1/2-3 ●		R3/8	35	12			22	
ESH-1/2-4 ●		R1/2	38	15			22	

●:印の機種は受注生産品です。
●:Production on order.

ステンレス製締付継手

黄銅製締付継手

PEEK製継手

ステンレス製
カップル

ステンレス製
チェックバルブ

ステンレス製
スピードコントローラー

ステンレス製
ニードルバルブ

ミニコア
フィッティング

ワンタッチ継手

スピードコントローラー
AQバルブ

ESL (エルボユニオン)

Male Elbow

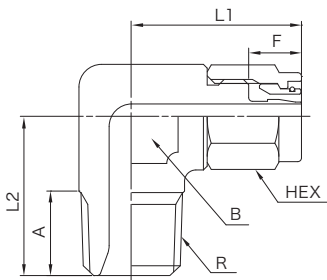

型番 Model No.	適用チューブ 外径×内径 Applicable tube O.D.×I.D.	R (PT)	L1	L2	A	F	最小穴径 Diameter of the min. hole	HEX	B
ESL-3216-1 ●	3.2×1.6	R1/8	20	18	9	6	1	10	12
ESL-0402-1 ●	4×2	R1/8	20	18	9	6	1.4	10	12
ESL-0402-2 ●		R1/4	21	21	11				14
ESL-1613-3 ●	16×13	R3/8	31	27	12	10.5	9.4	22	22
ESL-1613-4 ●		R1/2		30	15		11.9		
ESL-3/16-1 ●	4.76×3.48	R1/8	20	18	9	6	2.8	10	12
ESL-3/16-2 ●		R1/4	21	21	11				14
ESL-1/4-1 ●	6.35×4.57	R1/8	21.5	18	9	7	3.9	12	12
ESL-1/4-2 ●		R1/4	22.5	21	11				14
ESL-5/16-1 ●	7.94×5.9	R1/8	24	19	9	7.5	5.4	14	14
ESL-5/16-2 ●		R1/4		21	11				17
ESL-5/16-3 ●		R3/8		25	12				17
ESL-3/8-2 ●	9.53×6.99	R1/4	26.5	22	11	8	6.3	17	17
ESL-3/8-3 ●		R3/8		23	12				17
ESL-1/2-2 ●	12.7×9.56	R1/4	30	26	11	9.5	7.9	21	22
ESL-1/2-3 ●		R3/8		27	12		8.8		
ESL-1/2-4 ●		R1/2		30	15		8.8		

●:印の機種は受注生産品です。
●:Production on order.

ess/ESS (ストレートユニオン)

Equal Union

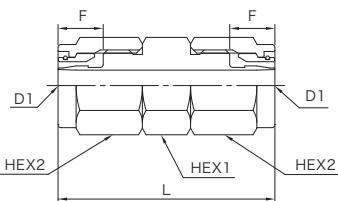

型番 Model No.	D1 (適用チューブ) (外径×内径) Applicable tube O.D.×I.D.	L	F	最小穴径 Diameter of the min. hole	HEX1	HEX2
ess-0425-0	4×2.5	28	6	1.9	10	10
ess-0604-0	6×4	32	7	3.2	12	12
ess-0805-0	8×5	36	7.5	4.2	14	14
ess-0806-0	8×6			5.2		
ess-1065-0	10×6.5	40	8	5.9	17	17
ess-1075-0	10×7.5			6.9		
ess-1008-0	10×8			7.4		
ess-1208-0	12×8	44	9.5	7.2	17	19
ess-1209-0	12×9			8.2		
ess-1210-0	12×10			9.2		
ESS-1/4-0 ●	6.35×4.57	32	7	3.9	12	12
ESS-5/16-0 ●	7.94×5.9	36	7.5	5.3	14	14
ESS-3/8-0 ●	9.53×6.99	40	8	6.3	17	17
ESS-1/2-0 ●	12.7×9.56	44	9.5	8.8	19	21

●:印の機種は受注生産品です。
●:Production on order.

ESS (異径ストレートユニオン)

Reducing Equal Union

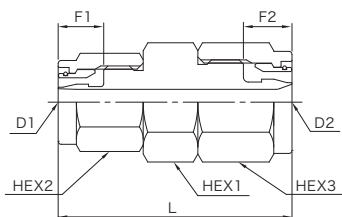

型番 Model No.	D1 (適用チューブ) (外径×内径) Applicable tube O.D.×I.D.	D2 (適用チューブ) (外径×内径) Applicable tube O.D.×I.D.	L	F1	F2	最小穴径 Diameter of the min. hole	HEX1	HEX2	HEX3			
ESS-0425×0604-0 ●	4×2.5	6×4	30.5	6	7	1.9	12	10	12			
ESS-0425×0806-0 ●		8×6	33		7.5		14		14			
ESS-0604×0805-0 ●	6×4	8×5	34.5	7	7.5	3.4	14	12	14			
ESS-0604×0806-0 ●		8×6			8		17		17			
ESS-0604×1008-0 ●		10×8	37		17		17					
ESS-0805×0806-0 ●	8×5	8×6	36	7.5	7.5	4.4	14	14	14			
ESS-0805×1065-0 ●		10×6.5	38.5		8		17		14			
ESS-0806×1075-0 ●	8×6	10×7.5	38.5	7.5	8	5.4	17	14	17			
ESS-0806×1008-0 ●		10×8							41	9.5	19	
ESS-0806×1209-0 ●		12×9	43		8				5.9	17	17	17
ESS-0806×1210-0 ●		12×10										6.9
ESS-1065×1008-0 ●	10×6.5	10×8	43	8	5.9	17	17	17				
ESS-1075×1209-0 ●	10×7.5	12×9	42.5	8	9.5	7.2	17	17	19			
ESS-1008×1208-0 ●	10×8	12×8				7.4						
ESS-1008×1209-0 ●		12×9	46	9.5	9.5	7.2	17	19	19			
ESS-1008×1210-0 ●	12×10	38.5	7.5	8	5.4	17	14	17				
ESS-0806×3/8-0 ●	8×6	9.53×6.99	38.5	7.5	8	5.4	17	14	17			
ESS-1008×3/8-0 ●	10×8		40	8	6.3	17	17					
ESS-1/4×5/16-0 ●	6.35×4.57	7.94×5.9	34.5	7	7.5	3.9	14	12	14			
ESS-1/4×3/8-0 ●		9.53×6.99	37	7	8	3.9	17	12	17			
ESS-5/16×3/8-0 ●	7.94×5.9		38.5	7.5	8	5.3	17	14	17			
ESS-3/8×1/2-0 ●	9.53×6.99	12.7×9.56	42.5	8	9.5	6.3	19	17	21			

●: 印の機種は受注生産品です。
●: Production on order.

ステンレス製締付継手

黄銅製締付継手

PEEK製継手

ステンレス製
カップル

ステンレス製
チエックバルブ

ステンレス製
スピードコントローラー

ステンレス製
ニードルバルブ

ミニチュア
フィッティング

ワンタッチ継手

スピードコントローラー
AQバルブ

ese/ESE (隔壁ユニオン)

Bulkhead Union

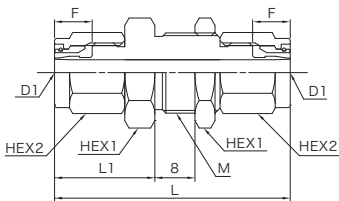

型番 Model No.	D1 (適用チューブ) (外径×内径) Applicable tube O.D.×I.D.	M	L	L1	F	最小穴径 Diameter of the min. hole	HEX1	HEX2
ese-0425-0	4×2.5	M12×1.0	41	17	6	1.9	14	10
ese-0604-0	6×4	M14×1.0	44	18.5	7	3.2	17	12
ese-0805-0	8×5	M16×1.0	47	20	7.5	4.2	19	14
ese-0806-0	8×6					5.2		
ese-1065-0	10×6.5	M18×1.0	50	21.5	8	5.9	22	17
ese-1075-0	10×7.5					6.9		
ese-1008-0	10×8					7.4		
ese-1208-0	12×8	M20×1.0	54	23	9.5	7.2	24	19
ese-1209-0	12×9					8.2		
ese-1210-0	12×10					9.2		
ESE-1613-0 ●	16×13	M24×1.0	56	24	10.5	11.9	29	22
ESE-1/4-0 ●	6.35×4.57	M14×1.0	44	18.5	7	3.9	17	12
ESE-5/16-0 ●	7.94×5.9	M16×1.0	47	20	7.5	5.3	19	14
ESE-3/8-0 ●	9.53×6.99	M18×1.0	50	21.5	8	6.3	22	17
ESE-1/2-0 ●	12.7×9.56	M20×1.0	54	23	9.5	8.8	24	21

●:印の機種は受注生産品です。

●: Production on order.

ESE (異径隔壁ユニオン)

Reducing Bulkhead Union

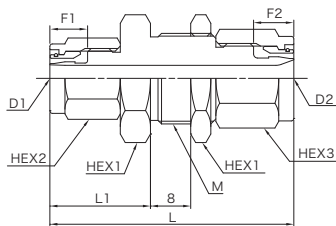

型番 Model No.	D1(適用チューブ) (外径×内径) Applicable tube O.D.×I.D.	D2(適用チューブ) (外径×内径) Applicable tube O.D.×I.D.	M	L	L1	F1	F2	最小穴径 Diameter of the min. hole	HEX1	HEX2	HEX3	
ESE-0402×0425-0 ●	4×2	4×2.5	M12×1.0	41	17	6	6	1.4	14	10	10	
ESE-0402×0604-0 ●		6×4	M14×1.0	42.5					17			
ESE-0425×0604-0 ●	4×2.5	8×6	M16×1.0	44					7.5			1.9
ESE-0425×0806-0 ●		10×8	M18×1.0	45.5	8	22	17					
ESE-0425×1008-0 ●		8×6	M16×1.0	45.5	18.5	7	7.5	19	14	17		
ESE-0604×0806-0 ●	6×4	10×8	M18×1.0	47	20	7.5	8	3.2	22	12	17	
ESE-0604×1008-0 ●		8×6	M16×1.0	48.5					8	14	17	
ESE-0805×1065-0 ●	8×5	10×6.5	M18×1.0	48.5	20	7.5	8	4.2	22	14	17	
ESE-0806×1008-0 ●	8×6	10×8	M18×1.0	48.5	20	7.5	8	5.2	22	14	17	
ESE-1008×1209-0 ●	10×8	12×9	M20×1.0	52.5	21.5	8	9.5	7.4	24	17	19	
ESE-1209×1065-0 ●	12×9	10×6.5	M20×1.0	52.5	23	9.5	8	5.9	24	19	17	
ESE-1209×1613-0 ●		16×13	M24×1.0	55					10.5	8.2	29	22
ESE-0604×3/8-0 ●	6×4	9.53×6.99	M18×1.0	47	18.5	7	8	3.4	22	12	17	
ESE-1/4×1008-0 ●	6.35×4.57	10×8		45.5				3.9				
ESE-3/16×1008-0 ●	4.76×3.48	7.94×5.9	M14×1.0	42.5	17	6	7	1.6	17	10	12	
ESE-1/8×1/4-0 ●	3.18×2.25			6.35×4.57				44				2.9
ESE-3/16×5/16-0 ●	4.76×3.48			M16×1.0				44				7.5
ESE-1/4×5/16-0 ●	6.35×4.57	M18×1.0	45.5	18.5	7	7.5	3.9	12	17	17		
ESE-5/16×3/8-0 ●	7.94×5.9	9.53×6.99	M20×1.0	48.5	20	7.5	8	5.3	22	14	17	
ESE-3/8×1/2-0 ●	9.53×6.99	12.7×9.56		52.5								21.5

●:印の機種は受注生産品です。
●:Production on order.

ステンレス製締付継手

黄銅製締付継手

PEEK製継手

ステンレス製
カップル

ステンレス製
チェックバルブ

ステンレス製
スピードコントローラー

ステンレス製
ニードルバルブ

ミニチュア
フィッティング

ワンタッチ継手

スピードコントローラー
AQバルブ

ESEH (隔壁ハーフユニオン)

Bulkhead Male Connector

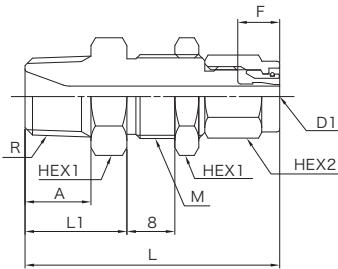

型番 Model No.	D1 (適用チューブ) (外径×内径) Applicable tube O.D.×I.D.	R (PT)	M	L	L1	A	F	最小穴径 Diameter of the min. hole	HEX1	HEX2
ESEH-0425-1 ●	4×2.5	R1/8	M12×1.0	39	15	9	6	1.9	14	10
ESEH-0425-2 ●		R1/4		41	17	11				
ESEH-0604-1 ●	6×4	R1/8	M14×1.0	40.5	15	9	7	3.4	17	12
ESEH-0604-2 ●		R1/4		42.5	17	11				
ESEH-0604-3 ●		R3/8		43.5	18	12				
ESEH-0806-1 ●	8×6	R1/8	M16×1.0	42	15	9	7.5	5.4	19	14
ESEH-0806-2 ●		R1/4		44	17	11				
ESEH-0806-3 ●		R3/8		45	18	12				
ESEH-1075-2 ●	10×7.5	R1/4	M18×1.0	45.5	17	11	8	6.9	22	17
ESEH-1075-3 ●		R3/8		46.5	18	12				
ESEH-1075-4 ●		R1/2		49.5	21	15				
ESEH-1008-2 ●	10×8	R1/4	M18×1.0	45.5	17	11	8	7.4	22	17
ESEH-1008-3 ●		R3/8		46.5	18	12				
ESEH-1008-4 ●		R1/2		49.5	21	15				
ESEH-1209-2 ●	12×9	R1/4	M20×1.0	48	17	11	9.5	8.2	24	19
ESEH-1209-3 ●		R3/8		49	18	12				
ESEH-1209-4 ●		R1/2		52	21	15				
ESEH-1210-2 ●	12×10	R1/4	M20×1.0	48	17	11	9.5	7.9	24	19
ESEH-1210-3 ●		R3/8		49	18	12				
ESEH-1210-4 ●		R1/2		52	21	15				

●:印の機種は受注生産品です。
●:Production on order.

ESEP (隔壁メスユニオン)

Bulkhead Female Connector

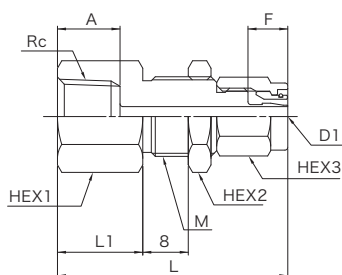

型番 Model No.	D1(適用チューブ) (外径×内径) Applicable tube O.D.xI.D.	Rc(PT)	M	L	L1	A	F	最小穴径 Diameter of the min. hole	HEX1	HEX2	HEX3
ESEP-0425-1 ●	4×2.5	Rc1/8	M12×1.0	35	11	9	6	1.9	14	14	10
ESEP-0425-2 ●		Rc1/4		39	15	11			17		
ESEP-0604-1 ●	6×4	Rc1/8	M14×1.0	36.5	11	9	7	3.4	17	17	12
ESEP-0604-2 ●		Rc1/4		40.5	15	11			22		
ESEP-0604-3 ●		Rc3/8		42.5	17	12			22		
ESEP-0806-1 ●	8×6	Rc1/8	M16×1.0	38	11	9	7.5	5.4	19	19	14
ESEP-0806-2 ●		Rc1/4		42	15	11			22		
ESEP-0806-3 ●		Rc3/8		44	17	12			22		
ESEP-1075-2 ●	10×7.5	Rc1/4	M18×1.0	43.5	15	11	8	6.9	22	22	17
ESEP-1075-3 ●		Rc3/8		45.5	17	12			27		
ESEP-1075-4 ●		Rc1/2		49.5	21	15			27		
ESEP-1008-2 ●		Rc1/4		43.5	15	11			22		
ESEP-1008-3 ●	10×8	Rc3/8	M18×1.0	45.5	17	12	8	7.4	22	22	17
ESEP-1008-4 ●		Rc1/2		49.5	21	15			27		
ESEP-1209-2 ●	12×9	Rc1/4	M20×1.0	46	15	11	9.5	8.2	24	24	19
ESEP-1209-3 ●		Rc3/8		48	17	12			27		
ESEP-1209-4 ●		Rc1/2		52	21	15			27		
ESEP-1210-2 ●	12×10	Rc1/4	M20×1.0	46	15	11	9.5	9.2	24	24	19
ESEP-1210-3 ●		Rc3/8		48	17	12			27		
ESEP-1210-4 ●		Rc1/2		52	21	15			27		

●:印の機種は受注生産品です。
●:Production on order.

ステンレス製締付継手

黄銅製締付継手

PEEK製継手

ステンレス製
カップル

ステンレス製
チェックバルブ

ステンレス製
スピードコントローラー

ステンレス製
ニードルバルブ

ミニコア
フィッティング

ワンタッチ継手

スピードコントローラー
AQバルブ

esf/ESF (両口エルボユニオン)

Union Elbow

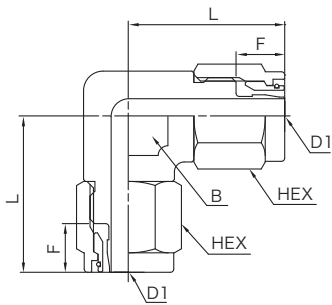

型番 Model No.	D1 (適用チューブ) (外径×内径) Applicable tube O.D.×I.D.	L	F	最小穴径 Diameter of the min. hole	HEX	B
esf-0425-0 ●	4×2.5	20	6	1.9	10	12
esf-0604-0 ●	6×4	21.5	7	3.4	12	12
esf-0805-0 ●	8×5	24	7.5	4.4	14	14
esf-0806-0 ●	8×6			5.4		
esf-1065-0 ●	10×6.5	26.5	8	5.9	17	17
esf-1075-0 ●	10×7.5			6.9		
esf-1008-0 ●	10×8			7.4		
esf-1208-0 ●	12×8	30	9.5	7.2	19	22
esf-1209-0 ●	12×9			8.2		
esf-1210-0 ●	12×10			9.2		
ESF-3/8-0 ●	9.53×6.99	26.5	8	6.3	17	17

●: 印の機種は受注生産品です。
●: Production on order.

ESF (異径両口エルボユニオン)

Reducing Union Elbow

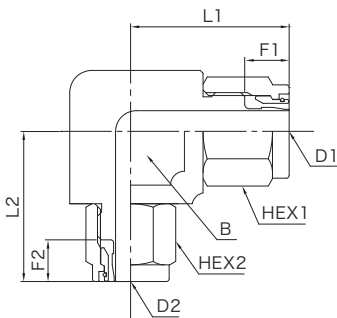

型番 Model No.	D1 (適用チューブ) (外径×内径) Applicable tube O.D.×I.D.	D2 (適用チューブ) (外径×内径) Applicable tube O.D.×I.D.	L1	L2	F1	F2	最小穴径 Diameter of the min. hole	HEX1	HEX2	B
ESF-0425×0604-0 ●	4×2.5	6×4	20	21.5	6	7	1.9	10	12	12
ESF-0806×0604-0 ●	8×6	6×4	25	23.5	7.5	7	3.4	14	12	17
ESF-0806×1008-0 ●		10×8	28.5	27		8	5.4		17	22
ESF-1209×1210-0 ●	12×9	12×10	33	30	9.5	9.5	8.2	19	19	22

●: 印の機種は受注生産品です。
●: Production on order.

espw/ESPW (メスユニオン)

Female Connector

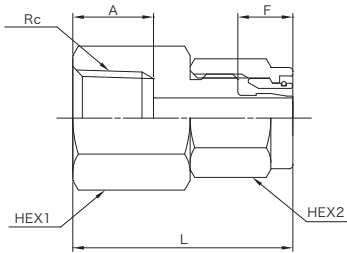

型番 Model No.	適用チューブ 外径×内径 Applicable tube O.D.×I.D.	Rc(PT)	L	A	F	最小穴径 Diameter of the min. hole	HEX1	HEX2
espw-0425-1 ●	4×2.5	Rc1/8	22	9	6	1.9	14	10
espw-0425-2 ●		Rc1/4	27	11			17	
espw-0604-1 ●	6×4	Rc1/8	23.5	9	7	3.4	14	12
espw-0604-2 ●		Rc1/4	28.5	11			17	
espw-0604-3 ●		Rc3/8	30.5	12			22	
espw-0805-1 ●	8×5	Rc1/8	25	8	7.5	4.4	14	14
espw-0805-2 ●		Rc1/4	30	11			17	
espw-0805-3 ●		Rc3/8	32	12			22	
espw-0806-1 ●	8×6	Rc1/8	25	8	7.5	5.4	14	14
espw-0806-2 ●		Rc1/4	30	11			17	
espw-0806-3 ●		Rc3/8	32	12			22	
espw-1065-2 ●	10×6.5	Rc1/4	31.5	11	8	5.9	17	17
espw-1065-3 ●		Rc3/8	33.5	12			22	
espw-1065-4 ●		Rc1/2	36.5	15			27	
espw-1075-2 ●	10×7.5	Rc1/4	31.5	11	8	6.9	17	17
espw-1075-3 ●		Rc3/8	33.5	12			22	
espw-1075-4 ●		Rc1/2	36.5	15			27	
espw-1008-2 ●	10×8	Rc1/4	31.5	11	8	7.4	17	17
espw-1008-3 ●		Rc3/8	33.5	12			22	
espw-1008-4 ●		Rc1/2	36.5	15			27	
espw-1208-2 ●	12×8	Rc1/4	33	11	9.5	7.2	19	19
espw-1208-3 ●		Rc3/8		12			22	
espw-1208-4 ●		Rc1/2	38	15			27	
espw-1209-2 ●	12×9	Rc1/4	33	11	9.5	7.9	19	19
espw-1209-3 ●		Rc3/8		12			22	
espw-1209-4 ●		Rc1/2	38	15			27	
espw-1210-2 ●	12×10	Rc1/4	33	11	9.5	9.2	19	19
espw-1210-3 ●		Rc3/8		12			22	
espw-1210-4 ●		Rc1/2	38	15			27	
ESPW-1/4-2 ●	6.35×4.57	Rc1/4	28.5	11	7	3.9	17	12

●:印の機種は受注生産品です。

●:Production on order.

esd/ESD (D型ユニオン)

D Type Connector

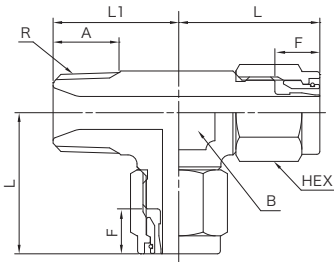

型番 Model No.	適用チューブ 外径×内径 Applicable tube O.D.×I.D.	R(PT)	L	L1	A	F	最小穴径 Diameter of the min. hole	HEX	B
esd-0425-1	4×2.5	R1/8	20	18	9	6	1.9	10	12
esd-0425-2		R1/4	21	21	11				14
esd-0604-1	6×4	R1/8	21.5	18	9	7	3.4	12	12
esd-0604-2		R1/4	22.5	21	11				14
esd-0604-3		R3/8	23.5	23	12				17
esd-0805-1	8×5	R1/8	23.5	19	9	7.5	4.4	14	14
esd-0805-2		R1/4		21	11				17
esd-0805-3		R3/8	25	23	12				17
esd-0806-1	8×6	R1/8	23.5	19	9	7.5	5.4	14	14
esd-0806-2		R1/4		21	11				17
esd-0806-3		R3/8	25	23	12				17
esd-1065-2	10×6.5	R1/4	28.5	25	11	8	5.9	17	22
esd-1065-3		R3/8		26	12				
esd-1065-4 ●		R1/2		29	15				
esd-1075-2 ●	10×7.5	R1/4	28.5	25	11	8	6.9	17	22
esd-1075-3 ●		R3/8		26	12				
esd-1075-4 ●		R1/2		29	15				
esd-1008-2	10×8	R1/4	28.5	25	11	8	7.4	17	22
esd-1008-3		R3/8		26	12				
esd-1008-4 ●		R1/2		29	15				
esd-1208-2	12×8	R1/4	30	26	11	9.5	7.2	19	22
esd-1208-3		R3/8		27	12				
esd-1208-4		R1/2		30	15				
esd-1209-2	12×9	R1/4	30	26	11	9.5	7.9	19	22
esd-1209-3		R3/8		27	12				
esd-1209-4		R1/2		30	15				
esd-1210-2	12×10	R1/4	30	26	11	9.5	7.9	19	22
esd-1210-3		R3/8		27	12				
esd-1210-4		R1/2		30	15				
ESD-1/4-1 ●	6.35×4.57	R1/8	21.5	18	9	7	3.9	12	12
ESD-1/4-2 ●		R1/4	22.5	21	11				14
ESD-3/8-2 ●	9.53×6.99	R1/4	28.5	25	11	8	6.3	17	22
ESD-3/8-3 ●		R3/8		26	12				
ESD-1/2-3 ●	12.7×9.56	R3/8	30	27	12	9.5	8.8	21	22
ESD-1/2-4 ●		R1/2		30	15				

●:印の機種は受注生産品です。
●:Production on order.

esc/ESC (C型ユニオン)

C Type Connector

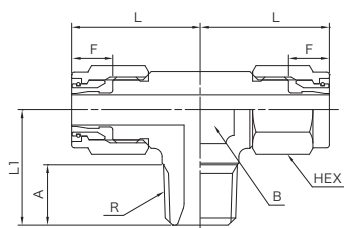

型番 Model No.	適用チューブ 外径×内径 Applicable tube O.D.×I.D.	R(PT)	L	L1	A	F	最小穴径 Diameter of the min. hole	HEX	B
esc-0425-1	4×2.5	R1/8	20	18	9	6	1.9	10	12
esc-0425-2		R1/4	21	21	11				14
esc-0604-1	6×4	R1/8	21.5	18	9	7	3.4	12	12
esc-0604-2		R1/4	22.5	21	11				14
esc-0604-3		R3/8	23.5	23	12				17
esc-0805-1	8×5	R1/8	23.5	19	9	7.5	4.4	14	14
esc-0805-2		R1/4		21	11				17
esc-0805-3		R3/8	25	23	12				17
esc-0806-1	8×6	R1/8	23.5	19	9	7.5	5.4	14	14
esc-0806-2		R1/4		21	11				17
esc-0806-3		R3/8	25	23	12				17
esc-1065-2	10×6.5	R1/4	28.5	25	11	8	5.9	17	22
esc-1065-3		R3/8		26	12				
esc-1065-4 ●		R1/2		29	15				
esc-1075-2 ●	10×7.5	R1/4	28.5	25	11	8	6.9	17	22
esc-1075-3 ●		R3/8		26	12				
esc-1075-4 ●		R1/2		29	15				
esc-1008-2	10×8	R1/4	28.5	25	11	8	7.4	17	22
esc-1008-3		R3/8		26	12				
esc-1008-4 ●		R1/2		29	15				
esc-1208-2	12×8	R1/4	30	26	11	9.5	7.2	19	22
esc-1208-3		R3/8		27	12				
esc-1208-4 ●		R1/2		30	15				
esc-1209-2	12×9	R1/4	30	26	11	9.5	7.9	19	22
esc-1209-3		R3/8		27	12				
esc-1209-4 ●		R1/2		30	15				
esc-1210-2	12×10	R1/4	30	26	11	9.5	7.9	19	22
esc-1210-3		R3/8		27	12				
esc-1210-4		R1/2		30	15				
ESC-1/4-1 ●	6.35×4.57	R1/8	21.5	18	9	7	3.9	12	12
ESC-1/4-2 ●		R1/4	22.5	21	11				14
ESC-3/8-2 ●	9.53×6.99	R1/4	28.5	25	11	8	6.3	17	22
ESC-3/8-3 ●		R3/8		26	12				
ESC-1/2-3 ●	12.7×9.56	R3/8	30	27	12	9.5	8.8	21	22
ESC-1/2-4 ●		R1/2		30	15				

●:印の機種は受注生産品です。
●:Production on order.

ステンレス製締付継手

黄銅製締付継手

PEEK製継手

ステンレス製
カップル

ステンレス製
チェックバルブ

ステンレス製
スピードコントローラー

ステンレス製
ニードルバルブ

ミニコア
フィッティング

ワンタッチ継手

スピードコントローラー
AQバルブ

est/EST (T型ユニオン)

T Type Union

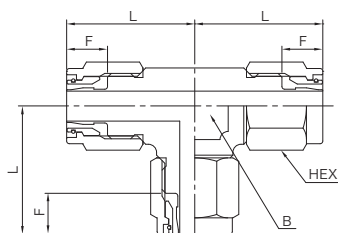

型番 Model No.	適用チューブ 外径×内径 Applicable tube O.D.×I.D.	L	F	最小穴径 Diameter of the min. hole	HEX	B
est-0425-0	4×2.5	20	6	1.9	10	12
est-0604-0	6×4	21.5	7	3.4	12	12
est-0805-0	8×5	23.5	7.5	4.4	14	14
est-0806-0	8×6			5.4		
est-1065-0	10×6.5	28.5	8	5.9	17	22
est-1075-0	10×7.5			6.9		
est-1008-0	10×8			7.4		
est-1208-0	12×8	30	9.5	7.2	19	22
est-1209-0	12×9			8.2		
est-1210-0	12×10			9.2		
EST-1/8-0 ●	3.18×2.25	20	6	1.6	10	12
EST-1/4-0 ●	6.35×4.57	21.5	7	3.9	12	12
EST-5/16-0 ●	7.94×5.9	23.5	7.5	5.3	14	14
EST-3/8-0 ●	9.53×6.99	28.5	8	6.3	17	22
EST-1/2-0 ●	12.7×9.56	30	9.5	8.8	21	22

●:印の機種は受注生産品です。

●:Production on order.

ESLD (エルユニオン)

L Type Connector

最高使用圧力:1MPa

Maximum working pressure:1MPa

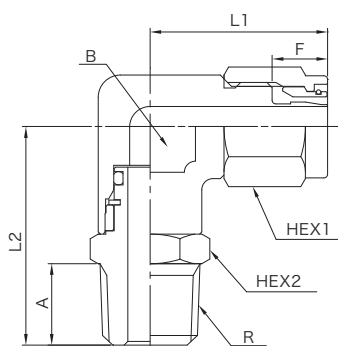

・Oリングには乾燥性組付け用ワックスを使用しています。 ・The O ring uses a dry assembly wax.

型番 Model No.	適用チューブ 外径×内径 Applicable tube O.D.×I.D.	R(PT)	L1	L2	A	F	最小穴径 Diameter of the min. hole	HEX1	HEX2	B
ESLD-0425-1 ●	4×2.5	R1/8	20	24.5	8	6	1.9	10	12	12
ESLD-0425-2 ●		R1/4		27.5	11				14	
ESLD-0604-1 ●	6×4	R1/8	21.5	25.5	8	7	3.4	12	12	12
ESLD-0604-2 ●		R1/4		29.5	12				14	
ESLD-0604-3 ●		R3/8		30					17	
ESLD-0805-1 ●	8×5	R1/8	24	26.5	8	7.5	4.4	14	14	14
ESLD-0805-2 ●		R1/4		29.5	11				17	
ESLD-0805-3 ●		R3/8		31.5	12				17	
ESLD-0806-1 ●	8×6	R1/8	24	26.5	8	7.5	5	14	14	14
ESLD-0806-2 ●		R1/4		29.5	11				17	
ESLD-0806-3 ●		R3/8		31.5	12				17	
ESLD-1065-2 ●	10×6.5	R1/4	26.5	31.5	11	8	5.9	17	17	17
ESLD-1065-3 ●		R3/8		33	12				22	
ESLD-1065-4 ●		R1/2		36	15				22	
ESLD-1075-2 ●	10×7.5	R1/4	26.5	31.5	11	8	6.9	17	17	17
ESLD-1075-3 ●		R3/8		33	12				22	
ESLD-1075-4 ●		R1/2		36	15				22	
ESLD-1008-2 ●	10×8	R1/4	26.5	31.5	11	8	7.4	17	17	17
ESLD-1008-3 ●		R3/8		33	12				22	
ESLD-1008-4 ●		R1/2		36	15				22	
ESLD-1208-2 ●	12×8	R1/4	30	33.5	11	9.5	7.2	19	19	22
ESLD-1208-3 ●		R3/8		34.5	12				22	
ESLD-1208-4 ●		R1/2		37.5	15				22	
ESLD-1209-2 ●	12×9	R1/4	30	33.5	11	9.5	8	19	19	22
ESLD-1209-3 ●		R3/8		34.5	12				22	
ESLD-1209-4 ●		R1/2		37.5	15				22	
ESLD-1210-2 ●	12×10	R1/4	30	33.5	11	9.5	8	19	19	22
ESLD-1210-3 ●		R3/8		34.5	12				22	
ESLD-1210-4 ●		R1/2		37.5	15				22	

●:印の機種は受注生産品です。

●:Production on order.

ステンレス製締付継手

黄銅製締付継手

PEEK製継手

ステンレス製
カップル

ステンレス製
チェックバルブ

ステンレス製
スピードコントローラー

ステンレス製
ニードルバルブ

ミニコア
フィッティング

ワンタッチ継手

スピードコントローラー
AQバルブ

ESLR (ターンエルボユニオン)

Turn Elbow

最高使用圧力:2MPa

Maximum working pressure:2MPa

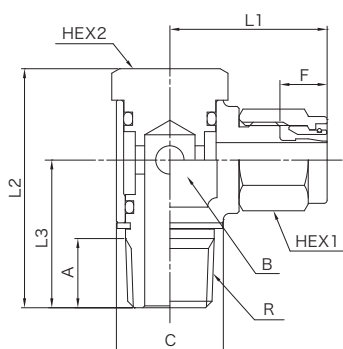

・Oリングには乾燥性組付け用ワックスを使用しています。 ・The O ring uses a dry assembly wax.

型番 Model No.	適用チューブ 外径×内径 Applicable tube O.D.×I.D.	R(PT)	L1	L2	L3	A	C	F	最小穴径 Diameter of the min. hole	HEX1	HEX2	B
ESLR-0425-1 ●	4×2.5	R1/8	20.5	31	18	8	φ14	6	1.9	10	13	14
ESLR-0604-1 ●	6×4	R1/8	22	31	18	8	φ14	7	3.4	12	13	14
ESLR-0604-2 ●		R1/4	23.5	38	23.5	11	φ17				15.87	17
ESLR-0805-1 ●	8×5	R1/8	23.5	31	18	8	φ14	7.5	3.5	14	13	14
ESLR-0805-2 ●		R1/4	25	38	23.5	11	φ17				15.87	17
ESLR-0805-3 ●		R3/8	27	45	27	12	φ22				19	22
ESLR-0806-1 ●	8×6	R1/8	23.5	31	18	8	φ14	7.5	3.5	14	13	14
ESLR-0806-2 ●		R1/4	25	38	23.5	11	φ17				15.87	17
ESLR-0806-3 ●		R3/8	27	45	27	12	φ22				19	22
ESLR-1065-3 ●	10×6.5	R3/8	28.5	45	27	12	φ22	8	5.9	17	19	22
ESLR-1075-3 ●	10×7.5								6			
ESLR-1008-3 ●	10×8								6			
ESLR-1208-3 ●	12×8	R3/8	30	45	27	12	φ22	9.5	6	19	19	22
ESLR-1209-3 ●	12×9											
ESLR-1210-3 ●	12×10											

●:印の機種は受注生産品です。

●:Production on order.

ESRN (ニードルバルブ)

Needle Valve

最高使用圧力:2MPa

Maximum working pressure:2MPa

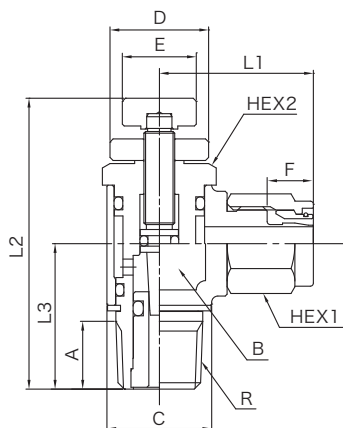

・Oリングには乾燥性組付け用ワックスを使用しています。 ・The O ring uses a dry assembly wax.

型番 Model No.	適用チューブ 外径×内径 Applicable tube O.D.×I.D.	R(PT)	L1	L2		L3	A	C	D	E	F	最小穴径 Diameter of the min. hole	HEX1	HEX2	B	
				Min	Max											
ESRN-0425-1 ●	4×2.5	R1/8	20.5	37.5	43	18	8	φ14	13	9	6	2.4	10	13	14	
ESRN-0604-1 ●	6×4	R1/8	22	37.5	43	18	8	φ14	13	9	7	2.4	12	13	14	
ESRN-0604-2 ●		R1/4	23.5	47.2	52.9	23.5	11	φ17	16	12				3.4	16	17
ESRN-0805-1 ●	8×5	R1/8	23.5	37.5	43	18	8	φ14	13	9	7.5	2.4	14	13	14	
ESRN-0805-2 ●		R1/4	25	47.2	52.9	23.5	11	φ17	16	12				3.4	16	17
ESRN-0805-3 ●		R3/8	27	54.7	61.2	27	12	φ22	19	14				4.4	19	22
ESRN-0806-1 ●	8×6	R1/8	23.5	37.6	43	18	8	φ14	13	9	7.5	2.4	14	13	14	
ESRN-0806-2 ●		R1/4	25	47.2	52.9	23.5	11	φ17	16	12				3.4	16	17
ESRN-0806-3 ●		R3/8	27	54.7	61.2	27	12	φ22	19	14				4.9	19	22
ESRN-1065-3 ●	10×6.5	R3/8	28.5	54.7	61.2	27	12	φ22	19	14	8	4.9	17	19	22	
ESRN-1075-3 ●	10×7.5															
ESRN-1008-3 ●	10×8															
ESRN-1208-3 ●	12×8	R3/8	30	54.7	61.2	27	12	φ22	19	14	9.5	4.9	19	19	22	
ESRN-1209-3 ●	12×9															
ESRN-1210-3 ●	12×10															

●:印の機種は受注生産品です。

●:Production on order.

LSH-□GNT-SL (パッキン使用ハーフユニオン)

Male Connector

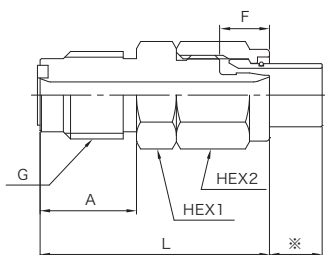

※ナット、スリーブ:材質:C3604BD(無電解Niメッキ)

The material of nut and sleeve is C3604BD.(Electroless Ni plating)

※印寸法については、「ロングスリーブタイプ寸法について」(14ページ)をご確認ください。

For the dimensions marked with ※, please refer to "A about long sleeve type dimensions" (page 14).

型番 Model No.	適用チューブ 外径×内径 Applicable tube O.D.×I.D.	G (PF)	L	A	F	最小穴径 Diameter of the min. hole	HEX1	HEX2
LSH-0402-2GNT-SL ●	4×2	G1/4	31.5	14.5	6	1.5	14	10
LSH-0425-2GNT-SL ●	4×2.5					1.9		
LSH-0604-2GNT-SL ●	6×4	G1/4	33	14.5	7	3.4	14	12
LSH-0604-3GNT-SL ●		G3/8	34.5	15.5			17	
LSH-0805-2GNT-SL ●	8×5	G1/4	34.5	14.5	7.5	4	14	14
LSH-0806-2GNT-SL ●	8×6					5.4		
LSH-0806-3GNT-SL ●	8×6	G3/8	36	15.5	8	6	17	17
LSH-1065-2GNT-SL ●	10×6.5	G1/4	36.5	14.5		4		
LSH-1075-2GNT-SL ●	10×7.5	G3/8	37.5	15.5	8	6	17	17
LSH-1075-3GNT-SL ●						4		
LSH-1008-2GNT-SL ●	10×8	G1/4	36.5	14.5	9.5	4	17	19
LSH-1008-3GNT-SL ●		G3/8	37.5	15.5		6		
LSH-1209-2GNT-SL ●	12×9	G1/4	38	14.5	9.5	4	17	19
LSH-1209-3GNT-SL ●		G3/8	39	15.5		6		
LSH-1210-2GNT-SL ●	12×10	G1/4	38	14.5	9.5	4	17	19
LSH-1210-3GNT-SL ●		G3/8	39	15.5		6		
LSH-1/8-2GNT-SL ●	3.18×2.25	G1/4	31.5	14.5	6	1.6	14	10
LSH-3/16-2GNT-SL ●	4.76×3.48	G1/4	31.5	14.5	6	2.5	14	10
LSH-1/4-2GNT-SL ●	6.35×4.57	G1/4	33	14.5	7	3.9	14	12
LSH-5/16-2GNT-SL ●	7.94×5.9	G1/4	34.5	14.5	7.5	4	14	14
LSH-5/16-3GNT-SL ●		G3/8	36	15.5		5.3	17	
LSH-3/8-2GNT-SL ●	9.53×6.99	G1/4	36.5	14.5	8	4	17	17
LSH-3/8-3GNT-SL ●		G3/8	37.5	15.5		6		
LSH-1/2-2GNT-SL ●	12.7×9.56	G1/4	38	14.5	9.5	4	19	21
LSH-1/2-3GNT-SL ●		G3/8	39	15.5		6		

●:印の機種は受注生産品です。

●:Production on order.

LSL-□GNT-SL (パッキン使用エルボユニオン)

Male Elbow

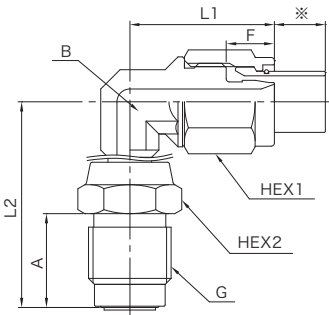

※ナット、スリーブ:材質:C3604BD(無電解Niメッキ)
The material of nut and sleeve is C3604BD.(Electroless Ni plating)

※印寸法については、「ロングスリーブタイプ寸法について」(14ページ)をご確認ください。
For the dimensions marked with ※, please refer to "A about long sleeve type dimensions"(page 14).

型番 Model No.	適用チューブ 外径×内径 Applicable tube O.D.×I.D.	G(PF)	L1	L2	A	F	最小穴径 Diameter of the min. hole	HEX1	HEX2	B
LSL-0402-2GNT-SL ●	4×2	G1/4	20	33.5	14.6	6	1.5	10	14	12
LSL-0425-2GNT-SL ●	4×2.5						1.9			
LSL-0604-2GNT-SL ●	6×4	G1/4	20	33.5	14.6	7	3.4	12	14	10
LSL-0806-2GNT-SL ●	8×6	G1/4	22.5	32	14.6	7.5	4	14	14	10
LSL-1075-2GNT-SL ●	10×7.5	G1/4	26.5	35.5	14.6	8	4	17	14	17
LSL-1008-2GNT-SL ●	10×8									10
LSL-1209-2GNT-SL ●	12×9	G1/4	28	35.5	14.6	9.5	4	19	14	17
LSL-1/8-2GNT-SL ●	3.18×2.25	G1/4	20	33.5	14.6	6	1.6	10	14	12
LSL-3/16-2GNT-SL ●	4.76×3.48	G1/4	20	33.5	14.6	6	2.8	10	14	12
LSL-1/4-2GNT-SL ●	6.35×4.57	G1/4	20	33.5	14.6	7	3.9	12	14	10
LSL-5/16-2GNT-SL ●	7.94×5.9	G1/4	22.5	32	14.6	7.5	4	14	14	10
LSL-3/8-2GNT-SL ●	9.53×6.99	G1/4	25.5	32	14.6	8	4	17	14	10

●:印の機種は受注生産品です。 注) 本体を固定して締付ける場合はネジが緩まないことを確認してください。
●:Production on order. When tightening with the body fixed, make sure that the screws do not loosen.

LSLL-□GNT-SL (パッキン使用ロングエルボユニオン)

Long Male Elbow



※ナット、スリーブ:材質:C3604BD(無電解Niメッキ)

The material of nut and sleeve is C3604BD.(Electroless Ni plating)

※印寸法については、「ロングスリーブタイプ寸法について」(14ページ)をご確認ください。

For the dimensions marked with ※, please refer to "A about long sleeve type dimensions" (page 14).

型番 Model No.	適用チューブ 外径×内径 Applicable tube O.D.×I.D.	G (PF)	L1	L2	A	F	最小穴径 Diameter of the min. hole	HEX1	HEX2	B
LSLL-0402-2GNT-SL ●	4×2	G1/4	21.5	51	14.6	6	1.5	10	14	10
LSLL-0425-2GNT-SL ●	4×2.5						1.9			
LSLL-0604-2GNT-SL ●	6×4	G1/4	20	51	14.6	7	3.4	12	14	10
LSLL-0806-2GNT-SL ●	8×6	G1/4	22.5	51	14.6	7.5	4	14	14	10
LSLL-1008-2GNT-SL ●	10×8	G1/4	25.5	51	14.6	8	4	17	14	10
LSLL-3/16-2GNT-SL ●	4.76×3.48	G1/4	21.5	51	14.6	6	2.8	10	14	10
LSLL-1/4-2GNT-SL ●	6.35×4.57	G1/4	20	51	14.6	7	3.9	12	14	10
LSLL-5/16-2GNT-SL ●	7.94×5.9	G1/4	22.5	51	14.6	7.5	4	14	14	10
LSLL-3/8-2GNT-SL ●	9.53×6.99	G1/4	25.5	51	14.6	8	4	17	14	10

●:印の機種は受注生産品です。 注) 本体を固定して締付ける場合はネジが緩まないことを確認してください。
●: Production on order. When tightening with the body fixed, make sure that the screws do not loosen.

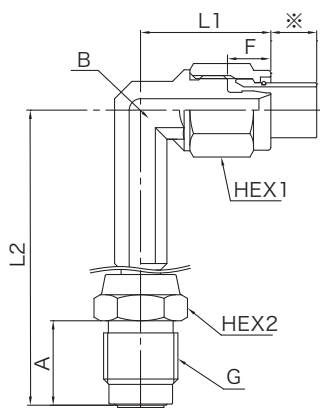

LS40L-□GNT-SL (パッキン使用40°エルボユニオン)

40° Male Elbow



※ナット、スリーブ:材質:C3604BD(無電解Niメッキ)

The material of nut and sleeve is C3604BD.(Electroless Ni plating)

※印寸法については、「ロングスリーブタイプ寸法について」(14ページ)をご確認ください。

For the dimensions marked with ※, please refer to "A about long sleeve type dimensions" (page 14).

型番 Model No.	適用チューブ 外径×内径 Applicable tube O.D.×I.D.	G (PF)	L1	L2	A	F	最小穴径 Diameter of the min. hole	HEX1	HEX2	B
LS40L-0604-2GNT-SL ●	6×4	G1/4	22.5	34.5	14.6	7	3.4	12	14	14
LS40L-0806-2GNT-SL ●	8×6	G1/4	24	34.5	14.6	7.5	4	14	14	14
LS40L-1008-2GNT-SL ●	10×8	G1/4	26.5	35.5	14.6	8	4	17	14	17

●:印の機種は受注生産品です。 注) 本体を固定して締付ける場合はネジが緩まないことを確認してください。
●: Production on order. When tightening with the body fixed, make sure that the screws do not loosen.

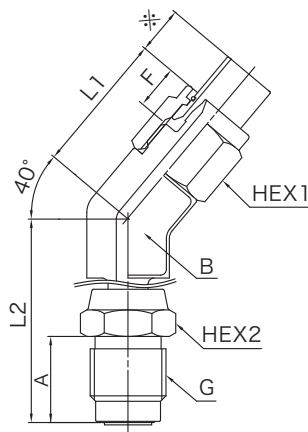

ステンレス製締付継手

黄銅製締付継手

PEEK製継手

ステンレス製
カップル

ステンレス製
チェックバルブ

ステンレス製
スピードコントローラー

ステンレス製
1/4"バルブ

ミニコア
フイティング

ワンタッチ継手

スピードコントローラー
AQバルブ

LSH-S□R-SL (スイベル ハーフユニオン)

Swivel Female Connector



※ナット、スリーブ: 材質: C3604BD (無電解Niメッキ)

The material of nut and sleeve is C3604BD. (Electroless Ni plating)

※印寸法については、「ロングスリーブタイプ寸法について」(14ページ)をご確認ください。

For the dimensions marked with ※, please refer to "A about long sleeve type dimensions" (page 14).

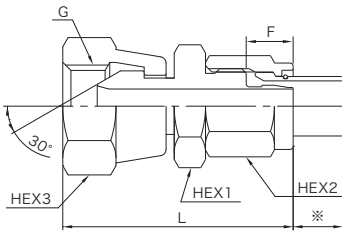

型番 Model No.	適用チューブ 外径×内径 Applicable tube O.D.×I.D.	G (PF)	L	F	最小穴径 Diameter of the min. hole	HEX1	HEX2	HEX3
LSH-0425-S2R-SL ●	4×2.5	G1/4	34.5	6	1.9	17	10	19
LSH-0425-S3R-SL ●		G3/8	35.5					22
LSH-0604-S2R-SL ●	6×4	G1/4	36	7	3.4	17	12	19
LSH-0604-S3R-SL ●		G3/8	37					22
LSH-0604-S2R-NPSM-SL ●		NPSM1/4	36					19
LSH-0806-S2R-SL ●	8×6	G1/4	37	7.5	5.4	17	14	19
LSH-0806-S3R-SL ●		G3/8	38.5					22
LSH-0806-S2R-NPSM-SL ●		NPSM1/4	37					19
LSH-0806-S3R-NPSM-SL ●		NPSM3/8	38.5					22
LSH-1075-S2R-SL ●	10×7.5	G1/4	39	8	5.9	17	17	19
LSH-1075-S3R-SL ●		G3/8	40.5		7.4			22
LSH-1008-S2R-SL ●	10×8	G1/4	39	8	5.9	17	17	19
LSH-1008-S3R-SL ●		G3/8	40.5		7.4			22
LSH-1008-S2R-NPSM-SL ●		NPSM1/4	39		5.9			19
LSH-1008-S3R-NPSM-SL ●		NPSM3/8	40.5		7.4			22
LSH-1209-S2R-SL ●	12×9	G1/4	40.5	9.5	5.9	17	19	19
LSH-1209-S3R-SL ●		G3/8	42.5		8.2			22
LSH-1210-S3R-SL ●	12×10	G3/8	41.5	9.5	9.2	17	19	22
LSH-1613-S3R-SL ●	16×13	G3/8	45.5	10.5	8.4	22	22	22
LSH-1/8-S2R-SL ●	3.18×2.25	G1/4	34.5	6	1.6	17	10	19
LSH-1/8-S3R-SL ●		G3/8	35.5					22
LSH-3/16-S2R-SL ●	4.75×3.15	G1/4	34.5	6	2.5	17	10	19
LSH-3/16-S3R-NPSM-SL ●	4.76×3.48	NPSM3/8	35	6	2.8	17	10	22
LSH-1/4-S2R-SL ●	6.35×4.57	G1/4	36	7	3.9	17	12	19
LSH-1/4-S3R-SL ●		G3/8	37					22
LSH-1/4-S3R-NPSM-SL ●		NPSM3/8	37					22
LSH-5/16-S2R-SL ●	7.94×5.9	G1/4	37	7.5	5.3	17	14	19
LSH-5/16-S3R-SL ●		G3/8	38.5					22
LSH-5/16-S3R-NPSM-SL ●		NPSM3/8	38.5					22
LSH-3/8-S2R-SL ●	9.53×6.99	G1/4	39	8	6	17	17	19
LSH-3/8-S3R-SL ●		G3/8	40.5		6.3			22
LSH-3/8-S3R-NPSM-SL ●		NPSM3/8	40.5		22			
LSH-1/2-S2R-SL ●	12.7×9.56	G1/4	41	9.5	6	19	21	19
LSH-1/2-S3R-SL ●		G3/8	42.5		8.4			22
LSH-1/2-S3R-NPSM-SL ●		NPSM3/8	42.5		22			

●: 印の機種は受注生産品です。

●: Production on order.

LSL-S□R-SL (スイベル エルボユニオン)

Swivel Elbow Connector

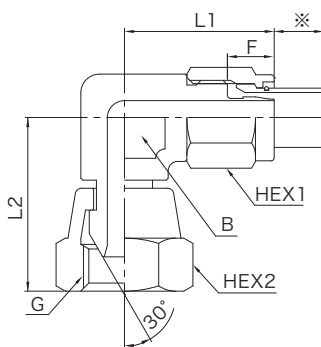

※ナット、スリーブ:材質:C3604BD(無電解Niメッキ)

The material of nut and sleeve is C3604BD.(Electroless Ni plating)

※印寸法については、「ロングスリーブタイプ寸法について」(14ページ)をご確認ください。

For the dimensions marked with ※, please refer to "A about long sleeve type dimensions" (page 14).

型番 Model No.	適用チューブ 外径×内径 Applicable tube O.D.×I.D.	G (PF)	L1	L2	F	最小穴径 Diameter of the min. hole	HEX1	HEX2	B
LSL-0425-S2R-SL	4×2.5	G1/4	20	27	6	1.9	10	19	12
LSL-0425-S3R-SL		G3/8	22	30.5					
LSL-0425-S2R-NPSM-SL		NPSM1/4	20	27					
LSL-0604-S2R-SL	6×4	G1/4	21.5	27	7	3.4	12	19	12
LSL-0604-S3R-SL		G3/8	23.5	30.5					
LSL-0604-S2R-NPSM-SL		NPSM1/4	21.5	27					
LSL-0604-S3R-NPSM-SL		NPSM3/8	23.5	30.5					
LSL-0806-S2R-SL	8×6	G1/4	24	28	7.5	5.4	14	19	14
LSL-0806-S3R-SL		G3/8	25	30.5					
LSL-0806-S3R-NPSM-SL		NPSM3/8							
LSL-1075-S2R-SL	10×7.5	G1/4		29	8	6.9	17	19	17
LSL-1075-S3R-SL		G3/8		30.5					
LSL-1008-S2R-SL	10×8	G1/4	26.5	29	8	7.4	19	19	17
LSL-1008-S3R-SL		G3/8		30.5					
LSL-1008-S3R-NPSM-SL		NPSM3/8							
LSL-1209-S2R-SL	12×9	G1/4	28	29	9.5	5.9	19	19	17
LSL-1209-S3R-SL		G3/8		30.5					
LSL-1210-S2R-SL	12×10	G1/4	30	33	8	8.2	22	19	22
LSL-1210-S3R-SL		G3/8	28	30.5					
LSL-1613-S3R-SL	16×13	G3/8	31	33.5	10.5	8.4	22	22	22
LSL-1/8-S2R-SL	3.18×2.25	G1/4	20	27	6	1.6	10	19	12
LSL-1/8-S3R-SL		G3/8	22	30.5					
LSL-3/16-S3R-NPSM-SL	4.76×3.48	NPSM3/8	22	30.5	6	2.8	10	22	17
LSL-1/4-S2R-SL	6.35×4.57	G1/4	21.5	27	7	3.9	12	19	12
LSL-1/4-S3R-SL		G3/8	23.5	30.5					
LSL-1/4-S3R-NPSM-SL		NPSM3/8							
LSL-5/16-S2R-SL	7.94×5.9	G1/4	24	28	7.5	5.3	14	19	14
LSL-5/16-S3R-SL		G3/8	25	30.5					
LSL-5/16-S3R-NPSM-SL		NPSM3/8							
LSL-3/8-S2R-SL	9.53×6.99	G1/4		29	8	6.3	17	19	17
LSL-3/8-S3R-SL		G3/8	26.5	30.5					
LSL-3/8-S3R-NPSM-SL		NPSM3/8							
LSL-1/2-S2R-SL	12.7×9.56	G1/4		32	9.5	8.4	21	19	22
LSL-1/2-S3R-SL		G3/8	30	33.5					
LSL-1/2-S3R-NPSM-SL		NPSM3/8							

●:印の機種は受注生産品です。

●:Production on order.

ステンレス製締付継手

黄銅製締付継手

PEEK製継手

ステンレス製
カップル

ステンレス製
チェックバルブ

ステンレス製
スピードコントローラー

ステンレス製
ニードルバルブ

ミチコア
フィッティング

ワンタッチ継手

スピードコントローラー
AQバルブ

LSLL-S□R-SL (スイベル ロングエルボユニオン)

Swivel Long Elbow Connector



※ナット、スリーブ:材質:C3604BD(無電解Niメッキ)

The material of nut and sleeve is C3604BD.(Electroless Ni plating)

※印寸法については、「ロングスリーブタイプ寸法について」(14ページ)をご確認ください。

For the dimensions marked with ※, please refer to "A about long sleeve type dimensions" (page 14).

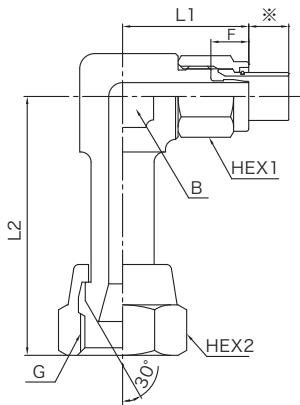

型番 Model No.	適用チューブ 外径×内径 Applicable tube O.D.×I.D.	G(PF)	L1	L2	F	最小穴径 Diameter of the min. hole	HEX1	HEX2	B
LSLL-0425-S2R-SL	4×2.5	G1/4	20	44	6	1.9	10	19	12
LSLL-0425-S3R-SL		G3/8	22	49.5				22	17
LSLL-0604-S2R-SL	6×4	G1/4	21.5	44	7	3.4	12	19	12
LSLL-0604-S3R-SL		G3/8	23.5	49.5				22	17
LSLL-0806-S2R-SL	8×6	G1/4	24	47.5	7.5	5.4	14	19	14
LSLL-0806-S3R-SL		G3/8	25	51.5				22	17
LSLL-1008-S2R-SL	10×8	G1/4	26.5	51.5	8	5.9	17	19	17
LSLL-1008-S3R-SL		G3/8		53				7.4	22
LSLL-1/4-S2R-SL	6.35×4.57	G1/4	21.5	44	7	3.9	12	19	12
LSLL-1/4-S3R-SL		G3/8	23.5	49.5				22	17
LSLL-5/16-S2R-SL	7.94×5.9	G1/4	24	47.5	7.5	5.3	14	19	14
LSLL-5/16-S3R-SL		G3/8	25	51.5				22	17
LSLL-3/8-S2R-SL	9.53×6.99	G1/4	26.5	51.5	8	5.9	17	19	17
LSLL-3/8-S3R-SL		G3/8		53				6.3	22

LSHR-S□R (スイベル Rネジユニオン)

Swivel R Screw Union

最高使用圧力:2MPa

Maximum working pressure:2MPa

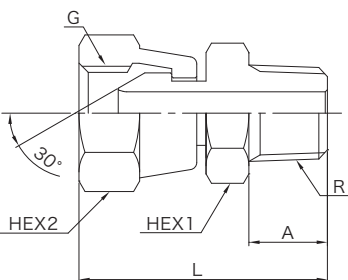

型番 Model No.		G(PF)	R(PT)	L	A	最小穴径 Diameter of the min. hole	HEX1	HEX2
LSHR-1/4-S2R	●	G1/4	R1/4	35	11	5.9	17	19
LSHR-1/4-S3R	●	G3/8		36.5		7.4		22
LSHR-1/4-S3R-NPSM	●	NPSM3/8						
LSHR-3/8-S2R	●	G1/4	R3/8	36	12	5.9	17	19
LSHR-3/8-S3R	●	G3/8		37.5		8		22
LSHR-3/8-S2R-NPSM	●	NPSM1/4		36		5.9		19
LSHR-3/8-S3R-NPSM	●	NPSM3/8		37.5		8		22

●:印の機種は受注生産品です。

●:Production on order.

LSHRC-S□R (スイベル RCネジユニオン)

Swivel RC Screw Union

最高使用圧力:2MPa

Maximum working pressure:2MPa

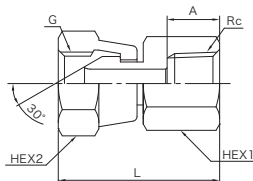

型番 Model No.	G (PF)	Rc (PT)	L	A	最小穴径 Diameter of the min. hole	HEX1	HEX2
LSHRC-1/4-S2R ●	G1/4	Rc1/4	34	11	5.9	17	19
LSHRC-1/4-S3R ●	G3/8		35.5		7.4		22
LSHRC-3/8-S2R ●	G1/4	Rc3/8	36	12	5.9	22	19
LSHRC-3/8-S3R ●	G3/8		37.5		8		22

●:印の機種は受注生産品です。

●:Production on order.

LSES-□SG (隔壁ネジユニオン)

Bulkhead Screw Union

最高使用圧力:2MPa

Maximum working pressure:2MPa

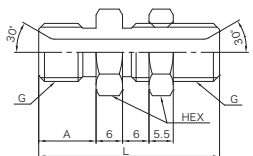

型番 Model No.	G (PF)	L	A	最小穴径 Diameter of the min. hole	HEX
LSES-2SG ●	G1/4	41	13	5.9	17
LSES-3SG ●	G3/8	45	15	8	22

●:印の機種は受注生産品です。

●:Production on order.

LSAL-□SG-S□R (スイベル L型ネジユニオン)

Swivel L Screw Union

最高使用圧力:2MPa

Maximum working pressure:2MPa

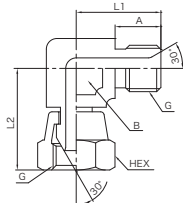

型番 Model No.	G (PF)	L1	L2	A	最小穴径 Diameter of the min. hole	HEX	B
LSAL-2SG-S2R ●	G1/4	29	24	13	5.9	19	17
LSAL-3SG-S3R ●	G3/8	30.5	26	15	8	22	17

●:印の機種は受注生産品です。

●:Production on order.

LSAD-□SG-S□R (スイベル D型ネジユニオン)

Swivel D Screw Union

最高使用圧力:2MPa

Maximum working pressure:2MPa



型番 Model No.	G (PF)	L	L1	A	最小穴径 Diameter of the min. hole	HEX	B
LSAD-2SG-S2R ●	G1/4	24	29	13	5.9	19	17
LSAD-3SG-S3R ●	G3/8	25	30.5	14	8	22	17

- :印の機種は受注生産品です。
- :Production on order.

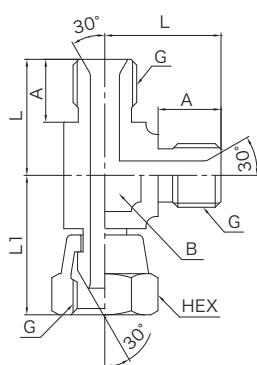

ES□-GW (ガードワイヤー付ユニオン)

Union with Guard Wire

- ・ガードワイヤー材質:SUS304 (SWC《亜鉛メッキ処理》)でも対応可能
Guard wire material: Although it is SUS304, SWC (zinc plating) is also available.
- ・ハーフユニオンをベース機種として寸法を記載していますが、他の機種にも対応可能です。
(L1はベース機種により異なります。)
The dimensions are listed with the male connector as the base model, but other models are also available.
(L1 varies depending on the base model.)
- ・ガードワイヤーの長さ、線径、材質についてご指定がある場合はお問合せください。
Please contact us if you would like to specify the length, wire diameter, or material of the guard wire.

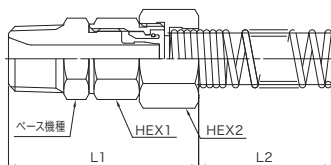

型番 Model No.	適用チューブ 外径×内径 Applicable tube O.D.×I.D.	ベース機種 Base model	L1	L2	HEX1	HEX2
ESH-0425-2GW ●	4×2.5	ESH-0425-2	35	85	10	12
ESH-0604-2GW ●	6×4	ESH-0604-2	38.5	85	12	14
ESH-0805-1GW ●	8×5	ESH-0805-1	36	85	14	17
ESH-0806-2GW ●	8×6	ESH-0806-2	38			
ESH-1008-2GW ●	10×8	ESH-1008-2	39	85	17	19
ESH-1/4-2GW ●	6.35×4.57	ESH-1/4-2	36	85	12	14

- :印の機種は受注生産品です。
- :Production on order.

スリーブ一体ナット

Sleeve Integrated Nut

・esn/ESN-□A(es-fit 標準タイプ)

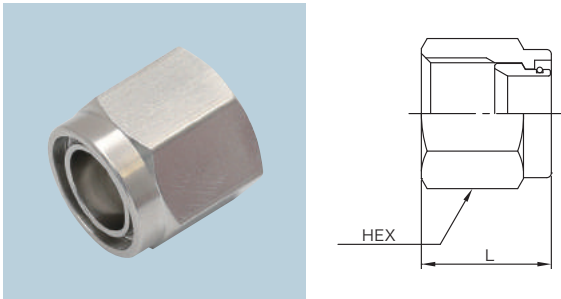

ナット、スリーブ材質：SUS316 The material of nut and sleeve is SUS316.

型番 Model No.	適用チューブ外径 Applicable tube O.D.	L	HEX
esn-04A	4	11	10
esn-06A	6	12.5	12
esn-08A	8	14	14
esn-10A	10	15.5	17
esn-12A	12	17	19
ESN-1/8A ●	3.18	11	10
ESN-3/16A ●	4.76	11	10
esn-1/4A ●	6.35	12.5	12
ESN-5/16A ●	7.94	14	14
esn-3/8A ●	9.53	15.5	17
esn-1/2A ●	12.7	17	21

●:印の機種は受注生産品です。
●:Production on order.

・LSN-□A-SL(LS-fit ロングスリーブタイプ)

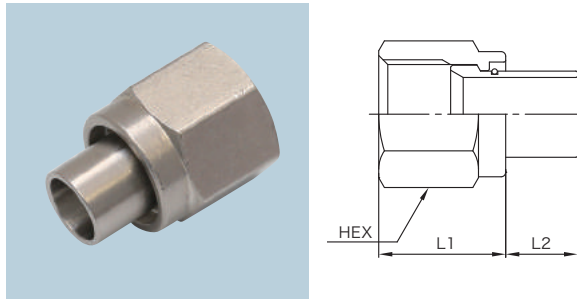

ナット、スリーブ材質：C3604BD(無電解Niメッキ)
The material of nut and sleeve is C3604BD.(Electroless Ni plating)

型番 Model No.	適用チューブ外径 Applicable tube O.D.	L1	L2	HEX
LSN-04A-SL ●	4	11	4	10
LSN-06A-SL ●	6	12.5	6	12
LSN-08A-SL ●	8	14	8	14
LSN-10A-SL ●	10	15.5	10	17
LSN-12A-SL ●	12	17	10	19
LSN-1/8A-SL ●	3.18	11	4	10
LSN-3/16A-SL ●	4.76	11	4	10
LSN-1/4A-SL ●	6.35	12.5	6	12
LSN-5/16A-SL ●	7.94	14	8	14
LSN-3/8A-SL ●	9.53	15.5	10	17
LSN-1/2A-SL ●	12.7	17	10	21

●:印の機種は受注生産品です。
●:Production on order.

・PSN-□A(PEEKタイプ)

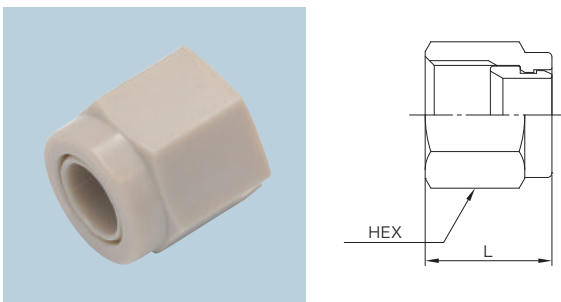

ナット、スリーブ材質：PEEK The material of nut and sleeve is PEEK.

型番 Model No.	適用チューブ外径 Applicable tube O.D.	L	HEX
PSN-06A ●	6	12.5	12
PSN-08A ●	8	14	14
PSN-10A ●	10	15.5	17
PSN-12A ●	12	17	19

●:印の機種は受注生産品です。
●:Production on order.

・ESN-□A-PK(ナットプラグタイプ)

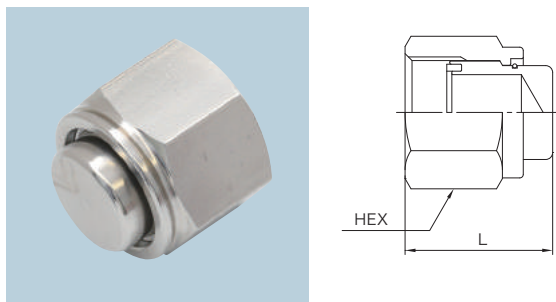

ナット、プラグ材質：SUS316 The material of nut and plug is SUS316.

型番 Model No.	適用継手径 Connecting fitting dia	L	HEX
ESN-12A-PK ●	12	11	19
ESN-1/2A-PK ●	12.7	21	21
ESN-3/4A-PK ●	19.05	26.4	27

●:印の機種は受注生産品です。
●:Production on order.

その他の製品

Other Products

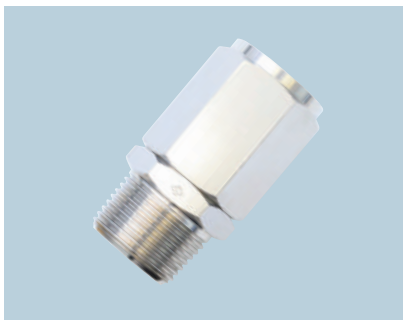

■ 大口径ハーフユニオン
(φ22×15、φ26×19)



■ 大口径両口エルボユニオン
(φ22×15、φ26×19)



■ 固定オリフィスユニオン



■ リリーフバルブ



■ パイプ溶接ユニオン

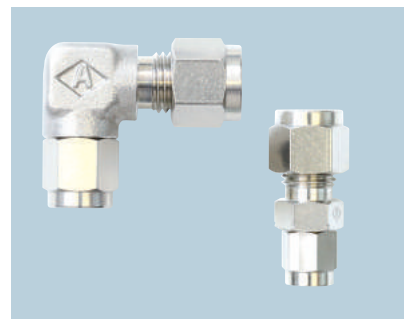

■ AW継手交換ユニオン

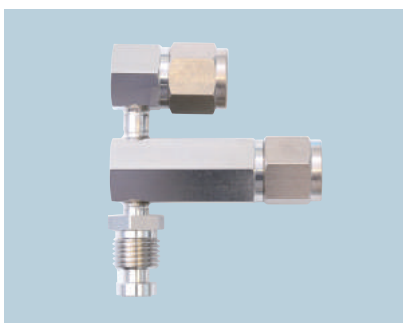

■ 2段エルボユニオン
溶接タイプ



■ C型ユニオン
溶接タイプ



■ エルボユニオン
溶接タイプ

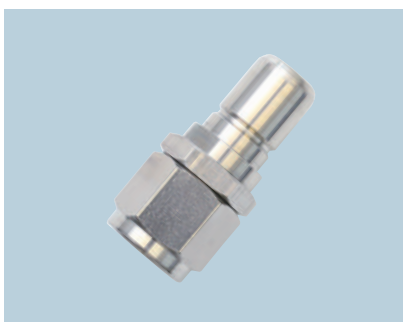

■ カップル.A一体ユニオン
プラグ



■ カップル.A一体ユニオン
ソケット



■ Oリングシールユニオン

BE BE-fit ブレードホース用締付継手

BE-FIT BRAIDED HOSE TIGHTENING JOINT

特長 Features

- 作業効率向上
Improve work efficiency.
- チャック機構によりホースをしっかり保持
The chuck mechanism holds the hose firmly in place.
- スリーブ・チャック・ナットが一体構造
The sleeve, chuck, and nut are integrated.
- アオイ独自のスリーブ構造により、配管時のチューブの捻じれを解消
AOI's original and unique sleeve structure eliminates twisting of the tube during piping.
- 液溜まりが少ない構造
Structure with little liquid accumulation.



■ 構造図 Internal Construction

仕様 Specifications

使用流体 Fluid used	空気、水、油、薬品 Air, Water, Oil, Chemicals
最高使用圧力 Maximum working pressure	1MPa (ホース最高使用圧力に準じます) Conforms to hose maximum working pressure
使用温度範囲 Operating temperature limit	-20°C~150°C (凍結不可、ホース使用温度範囲に準じます) Cannot be frozen, conforms to hose operating temperature range
負圧 negative pressure	-100kPa

適用ホース Applicable Hose

- ブレードホース(軟質塩化ビニル製ホース等)
Braided hose (Soft vinyl chloride hoses)

適用ホースサイズ Applicable Hose Size

(unit:mm)

ホース外径 Hose O.D.	外径×内径 O.D×I.D
φ11	11×6
φ13.5	13.5×8
φ16	16×10
φ18	18×12
φ22	22×15
φ26	26×19
φ33	33×25

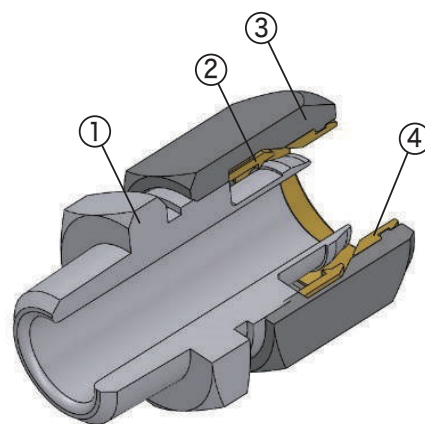

主要部品材質 Main Part Materials

No.	名称 Part Name	材質 Material
①	本体 Body	SUS316
②	チャック Chuck	PES
③	ナット(特殊ふっ素処理) Nut (fluorine treatment)	SUS316
④	スリーブ Sleeve	PES

型番表示方法 How to Designate

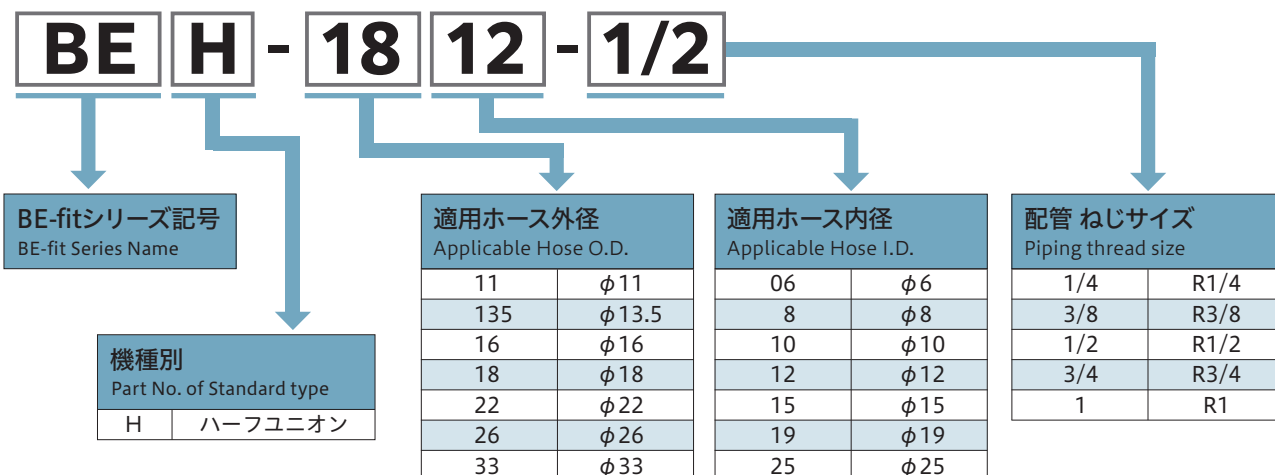

■ 外形寸法 External Dimension

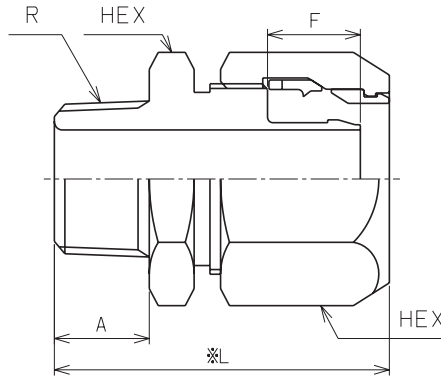

(unit:mm)

型番 Model No.	適用ホース 外径×内径 Applicable hose O.D.×I.D.	接続ネジ connection screw R	L	A	F	最小穴径 Minimum Opening	HEX
BEH-1106-1/4 ●	11 × 6	R1/4	50	13	14	5	21
BEH-1106-3/8 ●		R3/8	51	14			
BEH-1358-1/4 ●	13.5 × 8	R1/4	50	13	14	7	23
BEH-1358-3/8 ●		R3/8	51	14			
BEH-1610-3/8 ●	16 × 10	R3/8	55	14	14.9	8.5	27
BEH-1610-1/2 ●		R1/2	58	17			
BEH-1812-1/4 ●	18 × 12	R1/4	54	13	14.9	8	29
BEH-1812-3/8 ●		R3/8	55	14		11	
BEH-1812-1/2 ●		R1/2	58	17			
BEH-2215-1/4 ●	22 × 15	R1/4	58	13	17.6	8	35
BEH-2215-3/8 ●		R3/8	59	14		11	
BEH-2215-1/2 ●		R1/2	62	17		14	
BEH-2215-3/4 ●		R3/4	63	18			
BEH-2619-1/2 ●	26 × 19	R1/2	62.5	17	17.6	14	38
BEH-2619-3/4 ●		R3/4	63.5	18		17	
BEH-2619-1 ●		R1	67.5	22			
BEH-3325-3/4 ●	33 × 25	R3/4	64.5	18	18.5	17	46
BEH-3325-1 ●		R1	68.5	22		24	

※L寸法はナットを締付ける前の概略寸法を表わす。 L dimension represents the approximate dimension before tightening the nut.

●の機種は受注生産品です ●:Production on order.

■ 取付手順 Mounting Procedure

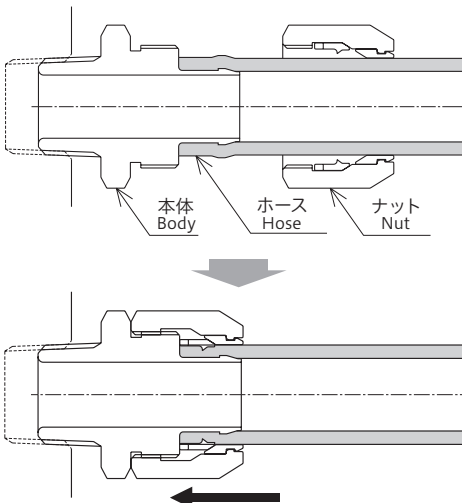

- ホースを直角に切断してください。
Please cut the hose perpendicularly.
- 本体とナットを分離させてください。※継手はセットされた状態で納品されます。
Please separate the main body and nut.
※The fitting is delivered as set.
- 本体Rねじ部を機器にスパナ等の工具を使用して締付けてください。
Please tighten the R-screw of the main body of the fitting to the equipment with a tool.
- ナットを通したホースを本体タケノコ部の根本まで挿入してください。
Please insert the hose through a nut to the root of the protrusion of the main body.
- スパナ等の工具にてナットを本体に突き当たるまで締め込んでください。
Please tighten a nut with spanner until it hits the main body.
- 再取り付けの際は、ナット内のチャック・スリーブに割れ等の異常がないことを確認してください。また、ブレードホースに有害なキズ等の異常がないことを確認してください。異常がない事を確認後、取付け手順(1)～(5)の方法で再度取付けを行ってください。
When reinstalling, make sure that there are no cracks or other abnormalities on the chuck or sleeve inside the nut. Also, confirm that there are no harmful scratches or other abnormalities on the braided hose. After confirming that there are no abnormalities, reinstall the hose according to the installation procedures (1) through (5).

⚠ 使用上の注意 Cautions for using

- この継手は国内の主たる樹脂ホースメーカーのブレードホース(補強材にテトロン糸やポリエステル糸を使用した軟質塩化ビニル製ホース等)を対象に開発された継手で、全てのブレードホースが使用できるわけではありません。*また、全てのブレードホースに同一の性能を発揮するものではありません。*
※ホースの補強材にワイヤー(金属・樹脂)を使用しているスプリングホースやサククションホース等にはご使用いただけません。詳細は弊社までお問合せください。
- This fitting was developed for the braided hoses of major domestic resin hose manufacturers i.e., soft PVC hoses that use tetron thread or polyester thread as the reinforcing materials. Not all braided hoses can be used.*
Also, it does not exhibit the same performance for all braided hoses.
※This product cannot be used with spring hoses and suction hoses that use metal or resin wires as hose reinforcements.Please contact us for details.

AW W-インターロック式締付継手(ステンレス製)

STAINLESS W-INTERLOCK JOINT AW

特長 Features

- 高圧・高温・低温に耐えられます。
Having resistance to high temperature, high pressure, and low temperature.
- 締付けトルクが小さく、捻れが生じない理想的なシールです。
Tightening torque is small, and no torsion is caused.
- 衝撃・振動に強いです。
Excellent resistance to a shock and vibration.
- ナットのねじ部に焼き付きを起こしません。
No seizing is caused in the screw part of a nut.
- 真空ラインに使用できます。
Can be used in the vacuum line.
- 繰り返し脱着に優れています。
Superior in desorption repeatedly.

材質 Material

この管継手を構成する、継手本体、ナット及びフェルールの材質は全て、SUS316を使用しております。

The material of all of the main body, nut, and ferrule is SUS316.

適用するパイプの種類 Applicable Pipe

JIS G 3459配管用ステンレス鋼鋼管に規定するSUS304TP、SUS316TPに準ずるステンレス鋼鋼管。

The stainless steel pipe corresponding to SUS316TP or SUS304TP specified as the stainless steel pipe for plumbing of JIS G 3459.

適用するパイプの基本条件 Basic conditions of the Applicable Pipe

パイプの外径寸法(O.D.) Outside diameter	3、4、6、8、10、12mm
外径許容差 O.D. Tolerance	±0.05mm
パイプの表面硬度 Surface hardness	HrB90以下(Hv190以下) HrB90 or less(Hv190 or less)
パイプの表面状態 Surface condition	肌あれ、キズなどの有害な欠陥が無きこと。 There must not be harmful defects, such as roughness or wound.

構造断面図 Internal Structure

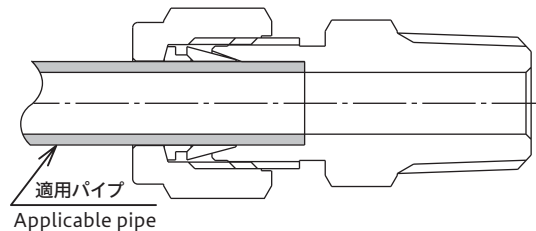

管継手の仕様/管厚圧力

Specifications/Pipe Thickness and Working Pressure

- 使用温度：-196℃～600℃
Operating temperature range：-196℃～600℃

- 使用圧力：下表参照
Working pressure：Please refer to the table below

パイプ外径 (mm) Pipe outside diameter	パイプ厚さ(mm) Pipe thickness			
	0.5	1	1.5	2
3	49.4	102.9	—	—
4	36.1	77.1	—	—
6	—	49.5	77.1	—
8	—	36.1	56.4	—
10	—	28.1	44.0	—
12	—	23.2	36.1	49.5

計算条件 Calculating conditions

※管材の最小引張値52.5kgf/mm² 安全率4

Minimum tensile strength value of pipe:52.5kgf/mm² Safety rate:4

※管厚さの許容値をZeroとした場合

※温度-29℃～37.8℃

Tolerance of tube thickness:0

Temperature:-29℃～37.8℃

適用チューブ Applicable Tube

アミドフレックス(AX-1200) AMIDFLEX (AX-1200)
スーパーフレックス(F-1500) Soft Nylon Tubes SUPERFLEX (F-1500)
ふっ素樹脂チューブ(FE) Fluorine Resin Tubes (FE)

※プラスチックチューブを接続する際はインサートリングを使用してください。
Please use an insert ring when connecting plastic tubes.

⚠ 使用上の注意 Cautions for using

1. パイプの切断は、パイプカッターにて直角に切断し、切断外周にバリがないよう充分に削り取ってください。
また、パイプ端から30mm以内にキズ、異物等がないように目視にて確認をしてください。
 2. ナットを締付ける際のスパナは、ナット六角径に合ったものを使用してください。
 3. 継手の取付角度を変える場合は、必ず継手のナットを緩めてから方向を変えてください。
 4. 高所及び配管スペースの狭い場所等で締付け困難な場合は、仮締付け作業を行い、締付け不足にならないように注意してください。
1. Please cut the pipe perpendicularly with the pipe cutter, and fully remove the flash from cutting perimeter.
Moreover, please confirm visually that there are no wound or foreign substance etc. within 30mm from the pipe ends.
 2. When tightening the nut, please use the spanner suitable for the diameter of the nut hexagon.
 3. When changing the attachment angle of the fitting, please be sure to change the direction after loosening the nut of the fitting
 4. If the tightening work is difficult in the high or narrow plumbing space, do temporary tightening work, and be sure not to become the shortage of tightening.

■ 締付け方法 Method of Tightening

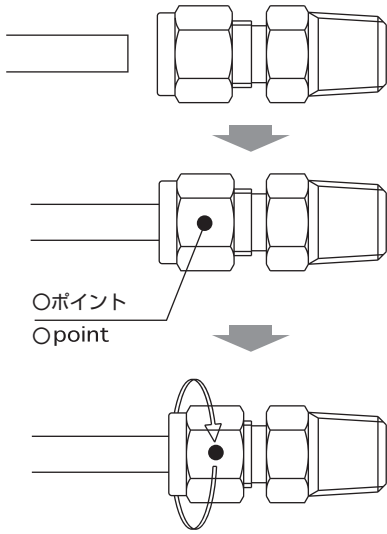

① ナットを外さないで、そのままパイプを継手の中に差し込み、パイプ先端を継手内部の肩にあたるまで、差し込んでください。(注:パイプは直角に切断し、端面の内外のバリは完全に取除いてあるか確認してください。)
Please insert the pipe, without removing a nut, into the fitting until the pipe tip hits the shoulder of the fitting inside. (Note : Please cut the pipe perpendicularly, and be sure that flash is fully removed from cutting perimeter.)

② ナットを手締めにて、回らなくなる迄締め込んでください。この位置をOポイントとし、目印をつけてください。
Please tighten the nut by hand until it stops. Please consider this position as Opoint and mark it.

③ 継手本体をスパナ等でしっかりと動かないように固定し、もう一本のスパナでナットを右記の回転数にて締め込んでください。
(注:本体を回転させての締め込みはしないでください。)
Please fix the main body of the fitting with a spanner well not to move. Then tighten the nut by another spanner at degrees written on the right.
(Note:Please do not turn the main body when tightening.)

● φ3、φ4 機種

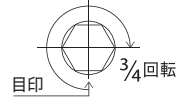

● φ6～φ12 機種

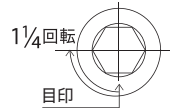

注意:プラスチックチューブを接続する際には、インサートリングを必ず併用して、φ4～φ12のチューブ締付け回転数は1¼～1½回転で締付けてください。

Note : When connecting the plastic tube, please be sure to use the insert ring together. For connecting φ4 ~ 12 plastic tube, please tighten 1¼ ~ 1½ turns (450 ~ 540 degrees.)

■ 取外し後の再締付け方法 Method of Re-tightening

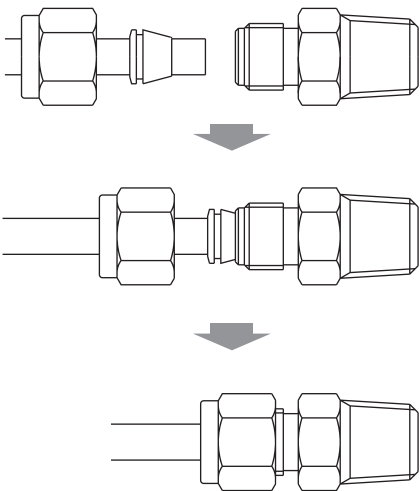

① ナットを緩める前にナットの位置を確認してからナットを外してください。(基準の締付回転位置)
Please loosen and remove a nut after checking the position of a nut.(The standard position of tightening.)

② フロントフェルールが正しい位置に装置されているか再確認してください。
Please reconfirm that the front ferrule is equipped to the correct position.

③ 再取り付け前に継手本体のテーパ面及びフロント、リア部に異物が付着していないことを確認してください。
Before reconnecting, please confirm that the foreign substances are not adhering to the taper side, the front, or the rear part of the body.

④ フロントフェルールが完全に継手本体のテーパシート面に密着するまで差し込んでからナットを手締めにて締付けてください(管端で本体テーパ部にスリ傷などつかないようにご注意の上、差し込んでください。)
Please tighten the nut by hand after inserting until the front ferrule sticks to the taper sheet side of the body completely.(When inserting, please be careful not to damage the taper part of the main body with the edge of pipe.)

⑤ 次にスパナにて、ナットを緩める前の位置よりわずかに多く締付けてください。(右記)
Then, please slightly tighten the nut with a spanner from the standard position of tightening.
(Please see the right diagram.)

注意:プラスチックチューブ使用時の再締付けにつきましては、1/8～1/4回転で締付けてください。
Note : When reconnecting the plastic tube, Please tighten 1/8 ~ 1/4 turn (45 ~ 90 degrees).

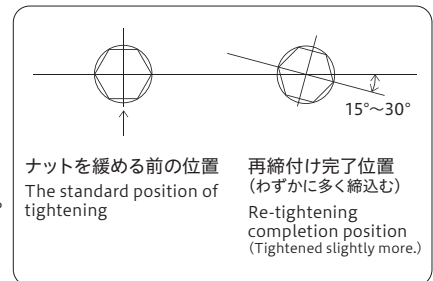

■ 配管上の注意 The Cautions on Plumbing

W-INTERLOCK JOINTはパイプ端を継手本体の管突き当て部に突き当てた状態で締付ける事が基本であり、その為には最小限の直管部が必要です。
Tightening the pipe in the condition that the pipe end bumps the "tube stop part" of the main body of the fitting is the foundation of W-INTERLOCK JOINT. Therefore the minimum straight pipe length (L) is required.

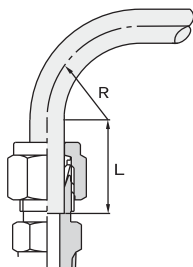

パイプ外径(mm) Pipe outside diameter	L(直管部最小寸法)(mm) L(Minimum straight length of pipe)	R(最小寸法)(mm) R(Minimum bending radius)
3	19	7
4	20	9
6	21	13.5
8	22	18
10	24	25
12	31	36

■ その他 Other

W-INTERLOCK JOINTは厳重な品質管理のもとで製作致しておりますが、万一、漏洩等発生した場合増し締めにて確認を行うとともに、詳しい使用状況、締付け状態等確認しながら原因究明致しますので、まずは弊社迄ご相談ください。

We are producing W-INTERLOCK JOINT under the severe quality control, but, if leakage etc. are generated by any chance, first of all, please consult us. We will cofirm it by tightening, and will investigate a cause with confirming the detailed situation of use, or the tightening state, etc.

■ 型番表示方法 How to Designate



W-インターロック式
締付継手シリーズ記号
W-INTERLOCK Series Name

機種別 Part No. of Standard Type		
H	ハーフユニオン	Male Connector
L	エルボユニオン	Male Elbow
F	両口エルボユニオン	Union Elbow
T	T型ユニオン	T Type Union
PT	T型メスユニオン	T Type Female Connector
C	C型ユニオン	C Type Connector
D	D型ユニオン	D Type Connector
S	ストレートユニオン	Equal Union
U	異径ユニオン	Reducing Union
R	レジュサー	Reducer
E	バルクヘッドユニオン	Bulkhead Union
EH	隔壁ハーフユニオン	Bulkhead Male Connector
EP	隔壁メスユニオン	Bulkhead Female Connector
P	圧力計ユニオン	Female Connector
PW	メスユニオン	Female Connector
N	袋ナット	Cap Nut
FF	フェルール (フロント)	Front Ferrule
FR	フェルール (リア)	Rear Ferrule
I	インサートリング	Insert Ring
DAW	PTパネル	PT Panel
VH	ミニチュアバルブ (H型)	Miniature Valve(H-Type)
VS	ミニチュアバルブ (S型)	Miniature Valve(S-Type)
VD	ミニチュアバルブ (D型)	Miniature Valve(D-Type)
VL	ミニチュアバルブ (L型)	Miniature Valve(L-Type)

適用パイプ外径 Applicable Pipe O.D.	
3	φ3
4	φ4
6	φ6
8	φ8
10	φ10
12	φ12

※インチサイズタイプの対応も
致します。(受注生産品)
We meet your demand of
inch-size type.

ねじの種類 Type of Screw	
表示なし None	R.Rc(PT)
N	NPT

※NPTねじタイプは受注生産品に
なります。
NTP screw type size will be
made to order.

ねじサイズ Screw size	
無記号 None	取付ねじ無し No Screw
0	
1	R.Rc(PT)1/8 or NPT1/8
2	R.Rc(PT)1/4 or NPT1/4
3	R.Rc(PT)3/8 or NPT3/8
4	R.Rc(PT)1/2 or NPT1/2

※NPTねじタイプは受注生産品になります。
NTP screw type size will be made to order.

※インチサイズについてはご相談ください。
Please inquire of us about inch-size type.

■ 推奨締付トルク Recommended Tightening Torque

ねじサイズ Screw(JIS B0203)	締付トルク(N・m) Tightening torque(N・m)
R1/8	7~9
R1/4	12~14
R3/8	22~24
R1/2	28~30

■ 製品の刻印表示 Stamping Display on Product

袋ナット ... マーク、適用パイプ外径 Cap nut ... Applicable pipe O.D.	本体 ... マーク、取付ねじサイズ Body ... Screw size
--	---

ねじサイズ Screw size

管形テーパねじ Taper pipe thread JIS B0203	おねじ External thread	R(PT)1/8	R(PT)1/4	R(PT)3/8	R(PT)1/2
管形平行ねじ Parallel pipe thread JIS B0203	めねじ Internal thread	Rc(PT)1/8	Rc(PT)1/4	Rc(PT)3/8	Rc(PT)1/2
	めねじ Internal thread	G(PF)1/8	G(PF)1/4	G(PF)3/8	G(PF)1/2
アメリカ管形ねじ American Standard pipe thread ANSI B2	おねじ External thread	NPT1/8	NPT1/4	NPT3/8	NPT1/2
	めねじ Internal thread				

●管形ねじNPT(ASA)の対応も致します。
We meet your demand of NPT(ASA) screw for pipe.

■ インチの識別

Identification of inch-size type

- AWH・AWS・AWUタイプのホース口側二面幅六角部の片側のみ45度面取りしています。
The corner parts of the hose connecting side of the main body of the AWH, AWS, and AWU type are chamfered (45°).
- AWL・AWF・AWTタイプのAマーク裏側にINCHマークを刻印しています。
(取り付けねじがあるものはINCHマークの下にねじサイズを刻印)
As for the AWL, AWF, and AWT type, the "INCH" mark is engraved on the back side of the "A" mark.
(Also the size of the screw is engraved under the "INCH" mark of the screw-type model.)

AWH (ハーフユニオン)

Male Connector

(unit: mm)

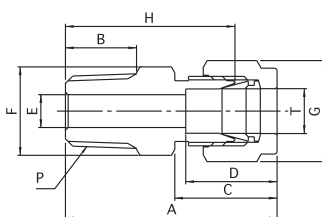

型番 Model No.	適用パイプ外径φ Applicable pipe O.D. T	P (R or NPT)	A	B	C	D	E	F (HEX)	G (HEX)	H	質量 (g) Mass
AWH-3-1	3	1/8	32.9	11	15.9	13.4	2.5	12	12	26	23
AWH-3-2		1/4	34.9	13				14		28	32
AWH-4-1	4	1/8	35.8	11	17.8	15.3	3.5	14	14	28.5	31
AWH-4-2		1/4	37.8	13						30.5	38
AWH-6-1	6	1/8	35.9	11	17.9	15.4	5	14	14	28.5	28
AWH-6-2		1/4	37.9	13				30.5		35	
AWH-6-3		3/8	38.9	14				31.5		49	
AWH-6-4		1/2	44.4	19				37		84	
AWH-8-1	8	1/8	36.8	11	18.8	16.8	5	15.87	15.87	29	31
AWH-8-2		1/4	38.8	13			31			44	
AWH-8-3		3/8	39.8	14			32			82	
AWH-8-4		1/2	45.3	19			37.5			85	
AWH-10-2	10	1/4	39.8	13	19.8	17.8	7	19	19	32	49
AWH-10-3		3/8	40.8	14			8			33	56
AWH-10-4		1/2	46.3	19			22			38.5	83
AWH-12-2	12	1/4	42.8	13	22.8	22.8	7	23	23	32	79
AWH-12-3		3/8	43.8	14			9			33	83
AWH-12-4		1/2	49.3	19			10			38.5	102

※NPTねじタイプは受注生産品になります。
NPT screw type size will be made to order.

(unit: mm)

型番 Model No.	適用パイプ外径φ Applicable pipe O.D. T	P (R)	A	B	C	D	E	F (HEX)	G (HEX)	H	質量 (g) Mass
AWH-1/8-1 ●	3.18	1/8	32.9	11	15.9	13.4	2.5	12	12	26	22
AWH-1/8-2 ●		1/4	34.9	13				14		28	32
AWH-1/4-1 ●	6.35	1/8	35.9	11	17.9	15.4	5	14	14	28.5	25
AWH-1/4-2 ●		1/4	37.9	13				30.5		32	
AWH-1/4-3 ●		3/8	38.9	14				31.5		46	
AWH-3/8-2 ●	9.53	1/4	39.8	13	19.8	17.8	7	19	19	32	48
AWH-3/8-3 ●		3/8	40.8	14			7.5			33	54
AWH-3/8-4 ●		1/2	46.3	19			22			38.5	101
AWH-1/2-2 ●	12.7	1/4	42.8	13	22.8	22.8	7	23	23	32	50
AWH-1/2-3 ●		3/8	43.8	14			9			33	65
AWH-1/2-4 ●		1/2	48.8	19			10			38	97

●:印の機種は受注生産品です。
●:Production on order.

AWL (エルボユニオン)

Male Elbow

(unit:mm)

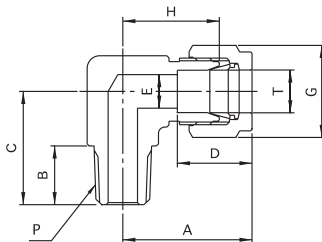

型番 Model No.	適用パイプ外径φ Applicable pipe O.D. T	P (R or NPT)	A	B	C	D	E	G (HEX)	H	質量 (g) Mass
AWL-3-1	3	1/8	24.9	11	22	13.4	2.5	12	18	32
AWL-4-1	4	1/8	27.8	11	22	15.3	3.5	14	20.5	45
AWL-4-2		1/4		13	24		3.5			52
AWL-6-1	6	1/8	27.9	11	22	15.4	5	14	20.5	50
AWL-6-2		1/4		13	24		5			44
AWL-6-3		3/8	28.9	14	27		5		21.5	78
AWL-6-4		1/2	30.9	17	35		5		23.5	149
AWL-8-1	8	1/8	28.8	11	22	16.8	5	15.87	21	47
AWL-8-2		1/4		13	24		6			52
AWL-8-3		3/8	29.8	14	27		6		22	79
AWL-8-4		1/2	31.8	17	35		6		24	149
AWL-10-2	10	1/4	30.8	13	27	17.8	7	19	23	76
AWL-10-3		3/8		14	27		8			81
AWL-10-4		1/2	32.8	17	35		8		25	151
AWL-12-2	12	1/4	35.8	13	28	22.8	7	23	25	132
AWL-12-3		3/8		14	30		9			86
AWL-12-4		1/2	17	35	10		159			

※NPTねじタイプは受注生産品になります。
NPT screw type size will be made to order.

(unit:mm)

型番 Model No.	適用パイプ外径φ Applicable pipe O.D. T	P (R)	A	B	C	D	E	G (HEX)	H	質量 (g) Mass
AWL-1/8-1 ●	3.18	1/8	24.9	11	22	13.4	2.5	12	18	32
AWL-1/8-2 ●		1/4	25.9	13	24				19	11
AWL-1/4-1 ●	6.35	1/8	27.9	11	22	15.4	5	14	20.5	41
AWL-1/4-2 ●		1/4	27.9	13	24				21.5	48
AWL-1/4-3 ●		3/8	28.9	14	27				23	63
AWL-3/8-2 ●	9.53	1/4	30.8	13	27	17.8	7	19	23	63
AWL-3/8-3 ●		3/8	30.8	14	27		7.5		80	
AWL-3/8-4 ●		1/2	32.8	17	35		7.5		161	
AWL-1/2-2 ●	12.7	1/4	35.8	13	28	22.8	7	23	25	105
AWL-1/2-3 ●		3/8		14	30		9			122
AWL-1/2-4 ●		1/2		17	35		10			153

●:印の機種は受注生産品です。
●:Production on order.

ステンレス製締付継手

黄銅製締付継手

PEEK製継手

ステンレス製
カップル

ステンレス製
チェックバルブ

ステンレス製
スピードコントローラー

ステンレス製
ニードルバルブ

ミニコア
フイティング

ワンタッチ継手

スピードコントローラー
AQバルブ

AWF (両口エルボユニオン)

Union Elbow

(unit:mm)

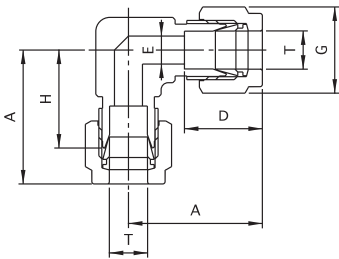

型番 Model No.	適用パイプ外径φ Applicable pipe O.D. T	A	D	E	G (HEX)	H	質量 (g) Mass
AWF-3-0	3	24.9	13.4	2.5	12	18	38
AWF-4-0	4	27.8	15.3	3.5	14	20.5	57
AWF-6-0	6	27.9	15.4	5	14	20.5	53
AWF-8-0	8	28.8	16.8	6	15.87	21	59
AWF-10-0	10	30.8	17.8	8	19	23	89
AWF-12-0	12	34.8	22.8	10	23	24	156

(unit:mm)

型番 Model No.	適用パイプ外径φ Applicable pipe O.D. T	A	D	E	G (HEX)	H	質量 (g) Mass
AWF-1/8-0 ●	3.18	24.9	13.4	2.5	12	18	38
AWF-1/4-0 ●	6.35	27.8	15.4	5	14	20.5	51
AWF-3/8-0 ●	9.53	30.8	17.8	8	19	23	87
AWF-1/2-0 ●	12.7	34.8	22.8	10	23	24	153

- :印の機種は受注生産品です。
- :Production on order.

AWT (T型ユニオン)

T Type Union

(unit:mm)



型番 Model No.	適用パイプ外径φ Applicable pipe O.D. T	A	D	E	G (HEX)	H	J	K	質量 (g) Mass
AWT-3-0	3	24.9	13.4	2.5	12	18	36	49.8	51
AWT-4-0	4	27.8	15.3	3.5	14	20.5	41	55.6	77
AWT-6-0	6	27.9	15.4	5	14	20.5	41	55.8	70
AWT-8-0	8	29.8	16.8	6	15.87	22	44	59.6	83
AWT-10-0	10	30.8	17.8	8	19	23	46	61.6	119
AWT-12-0	12	38.3	22.8	10	23	27.5	55	76.6	226

(unit:mm)

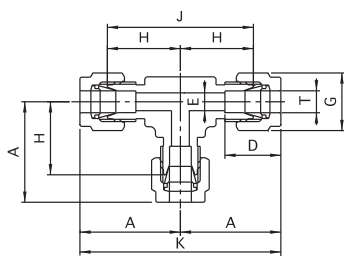

型番 Model No.	適用パイプ外径φ Applicable pipe O.D. T	A	D	E	G (HEX)	H	J	K	質量 (g) Mass
AWT-1/8-0 ●	3.18	24.9	13.4	2.5	12	18	36	49.8	51
AWT-1/4-0 ●	6.35	27.9	15.4	5	14	20.5	41	55.8	68
AWT-3/8-0 ●	9.53	30.8	17.8	8	19	23	46	61.6	115
AWT-1/2-0 ●	12.7	38.3	22.8	10	23	27.5	55	76.6	220

●:印の機種は受注生産品です。

●:Production on order.

ステンレス製締付継手

黄銅製締付継手

PEEK製継手

ステンレス製
カップル

ステンレス製
チェックバルブ

ステンレス製
スピードコントローラー

ステンレス製
ニードルバルブ

ミニチュア
フィッティング

ワンタッチ継手

スピードコントローラー
AQバルブ

AWPT (T型メスユニオン)

T Type Female Connector

(unit:mm)



型番 Model No.	適用パイプ外径φ Applicable pipe O.D. T	P (Rc or NPT)	A	B	D	E	G (HEX)	H	K	質量 (g) Mass
AWPT-3-1	3	1/8	26.9	22	13.4	2.5	12	40	53.8	48
AWPT-4-1	4	1/8	28.8	22	15.3	3.5	14	43	57.6	71
AWPT-6-1	6	1/8	28.9	22	15.4	5	14	43	57.8	65
AWPT-6-2	6	1/4	28.9	22	15.4	5	14	43	57.8	79
AWPT-8-2	8	1/4	29.8	22	16.8	6	15.87	44	59.6	86
AWPT-10-2	10	1/4	30.8	22	17.8	8	19	46	61.6	100
AWPT-12-3	12	3/8	38.3	27	22.8	10	23	55	76.6	197

※NPTねじタイプは受注生産品になります。
NPT screw type size will be made to order.

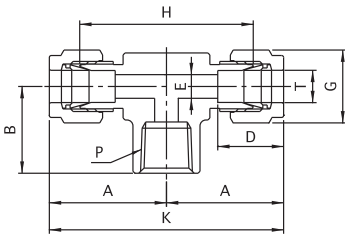

AWC (C型ユニオン)

C Type Connector

(unit:mm)



型番 Model No.	適用パイプ外径φ Applicable pipe O.D. T	P (R or NPT)	A	B	C	D	E	G (HEX)	H	J	K	質量 (g) Mass
AWC-3-1	3	1/8	24.9	11	21	13.4	2.5	12	18	36	49.8	45
AWC-4-1	4	1/8	27.8	11	21	15.3	3.5	14	20.5	41	55.6	64
AWC-6-1	6	1/8	27.9	11	21	15.4	5	14	20.5	41	55.8	60
AWC-6-2	6	1/4	28.9	13	23	15.4	5	14	21.5	43	57.8	69
AWC-8-1	8	1/8	29.8	11	22	16.8	5	15.87	22	44	59.6	68
AWC-8-2	8	1/4	29.8	13	23	16.8	6	15.87	22	44	59.6	73
AWC-10-2	10	1/4	30.8	13	25	17.8	7	19	23	46	61.6	103
AWC-12-3	12	3/8	38.3	14	30	22.8	9	23	27.5	55	76.6	199

※NPTねじタイプは受注生産品になります。
NPT screw type size will be made to order.

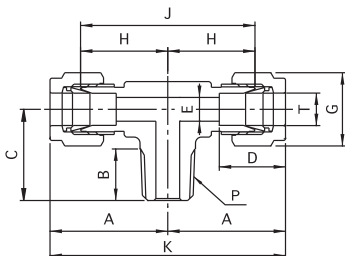

AWD (D型ユニオン)

D Type Connector

(unit:mm)

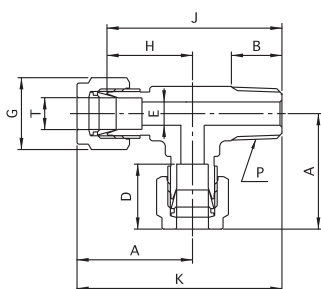

型番 Model No.	適用パイプ外径φ Applicable pipe O.D. T	P (R or NPT)	A	B	D	E	G (HEX)	H	J	K	質量 (g) Mass
AWD-3-1	3	1/8	24.9	11	13.4	2.5	12	18	39	45.9	45
AWD-4-1	4	1/8	27.8	11	15.3	3.5	14	20.5	41.5	48.8	65
AWD-6-1	6	1/8	27.9	11	15.4	5	14	20.5	41.5	48.9	43
AWD-6-2	6	1/4	28.9	13	15.4	5	14	21.5	44.5	51.9	69
AWD-8-1	8	1/8	29.8	11	16.8	6	15.87	22	44	51.8	68
AWD-8-2	8	1/4	29.8	13	16.8	6	15.87	22	45	52.8	73
AWD-10-2	10	1/4	30.8	13	17.8	8	19	23	48	55.8	102
AWD-12-3	12	3/8	38.3	14	22.8	10	23	27.5	57.5	68.3	199

※NPTねじタイプは受注生産品になります。
NPT screw type size will be made to order.

AWS (ストレートユニオン)

Equal Union

(unit:mm)

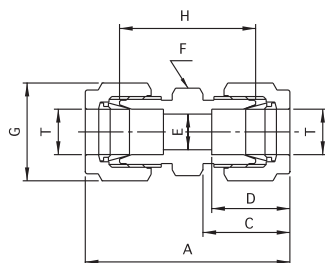

型番 Model No.	適用パイプ外径φ Applicable pipe O.D. T	A	C	D	E	F (HEX)	G (HEX)	H	質量 (g) Mass
AWS-3-0	3	37.8	15.9	13.4	2.5	12	12	24	27
AWS-4-0	4	42.6	17.8	15.3	3.5	14	14	28	31
AWS-6-0	6	42.8	17.9	15.4	5	14	14	28	38
AWS-8-0	8	44.6	18.8	16.8	6	14	15.87	29	49
AWS-10-0	10	46.6	19.8	17.8	8	17	19	31	68
AWS-12-0	12	52.6	22.8	22.8	10	22	23	31	111

(unit:mm)

型番 Model No.	適用パイプ外径φ Applicable pipe O.D. T	A	C	D	E	F (HEX)	G (HEX)	H	質量 (g) Mass
AWS-1/8-0 ●	3.18	37.8	15.9	13.4	2.5	12	12	24	27
AWS-1/4-0 ●	6.35	42.8	17.9	15.4	5	14	14	28	36
AWS-3/8-0 ●	9.53	46.6	19.8	17.8	7.5	17	19	31	63
AWS-1/2-0 ●	12.7	52.6	22.8	22.8	10	22	23	31	107

●:印の機種は受注生産品です。
●:Production on order.

ステンレス製締付継手

黄銅製締付継手

PEEK製継手

ステンレス製
カップル

ステンレス製
チェックバルブ

ステンレス製
スピードコントローラー

ステンレス製
ニードルバルブ

ミニコア
フィッティング

ワンタッチ継手

スピードコントローラー
AQバルブ

AWU (異径ユニオン)

Reducing Union

(unit: mm)



型番 Model No.	適用パイプ外径φ Applicable pipe O.D. T		A	C ₁	C ₂	D ₁	D ₂	E	F (HEX)	G ₁ (HEX)	G ₂ (HEX)	H	質量 (g) Mass
	T ₁	T ₂											
AWU-3.4-0	3	4	40.7	15.9	17.8	13.4	15.3	2.5	14	12	14	26.5	36
AWU-4.6-0	4	6	42.7	17.8	17.9	15.3	15.4	3.5	14	14	14	28	39
AWU-6.8-0	6	8	43.7	17.9	18.8	15.4	16.8	5	14	14	15.87	28.5	41
AWU-8.10-0	8	10	45.6	18.8	19.8	16.8	17.8	6	17	15.87	19	30	59
AWU-10.12-0	10	12	49.6	19.8	22.8	17.8	22.8	8	22	19	23	31	95

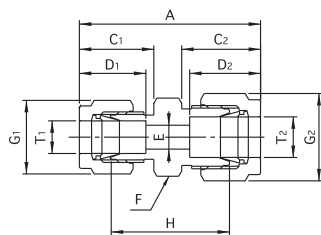

(unit: mm)

型番 Model No.	適用パイプ外径φ Applicable pipe O.D. T		A	C ₁	C ₂	D ₁	D ₂	E	F (HEX)	G ₁ (HEX)	G ₂ (HEX)	H	質量 (g) Mass
	T ₁	T ₂											
AWU-1/4.3/8-0 ●	6.35	9.53	44.7	17.9	19.8	15.4	17.8	5	17	14	19	29.5	53
AWU-1/4.1/2-0 ●	6.35	12.7	44.7	17.9	22.8	15.4	22.8	5	22	14	23	29.5	80

●: 印の機種は受注生産品です。

●: Production on order.

AWR (レジュースー)

Reducer

(unit: mm)



型番 Model No.	適用パイプ外径φ Applicable pipe O.D. T		A	C	D	E	F (HEX)	G (HEX)	H	質量 (g) Mass
	T ₁	T ₂								
AWR-3.4-0	3	4	40.9	15.9	13.4	2.5	12	12	34	18
AWR-3.6-0	3	6	40.9	15.9	13.4	2.5	12	12	34	19
AWR-4.6-0	4	6	43.8	17.8	15.3	3.5	14	14	36.5	27
AWR-4.8-0	4	8	43.8	17.8	15.3	3.5	14	14	36.5	28
AWR-6.8-0	6	8	43.9	17.9	15.4	5	14	14	36.5	26
AWR-6.10-0	6	10	48.9	17.9	15.4	5	14	14	41.5	28
AWR-8.10-0	8	10	49.8	18.8	16.8	6	14	15.87	42	31
AWR-8.12-0	8	12	53.8	18.8	16.8	6	14	15.87	46	33
AWR-10.12-0	10	12	54.8	19.8	17.8	8	17	19	47	46

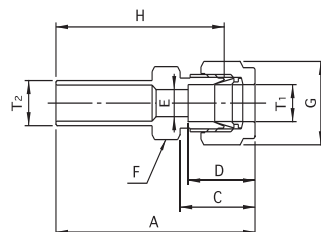

(unit: mm)

型番 Model No.	適用パイプ外径φ Applicable pipe O.D. T		A	C	D	E	F (HEX)	G (HEX)	H	質量 (g) Mass
	T ₁	T ₂								
AWR-1/8.1/4-0 ●	3.15	6.35	37.4	15.9	13.4	2.5	12	12	30.5	19
AWR-1/4.3/8-0 ●	6.35	9.53	48.9	17.9	15.4	5	14	14	41.5	28
AWR-1/4.1/2-0 ●	6.35	12.7	52.9	17.9	15.4	5	14	14	45.5	32
AWR-3/8.1/2-0 ●	9.53	12.7	54.8	19.8	17.8	7.5	17	19	47	50

●: 印の機種は受注生産品です。

●: Production on order.

AWE (バルクヘッドユニオン)

Bulkhead Union

(unit: mm)

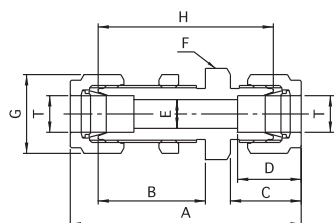

型番 Model No.	適用パイプ外径φ Applicable pipe O.D. T	A	B	C	D	E	F (HEX)	G (HEX)	H	取付穴径 Panel Hole Size	最大取付板厚 Max. Panel Thickness	質量 (g) Mass
AWE-3-0	3	49.8	22	15.9	13.4	2.5	14	12	36	8.5	10	37
AWE-4-0	4	59.6	28	17.8	15.3	3.5	17	14	45	11.5	13	59
AWE-6-0	6	59.8	28	17.9	15.4	5	17	14	45	11.5	13	53
AWE-8-0	8	62.6	29	18.8	16.8	6	17	15.87	47	13.2	13.5	66
AWE-10-0	10	64.6	30	19.8	17.8	8	22	19	49	16.2	14.5	98
AWE-12-0	12	73.6	32	22.8	22.8	10	26	23	52	19.5	16	164

AWEH (隔壁ハーフユニオン)

Bulkhead Male Connector

(unit: mm)

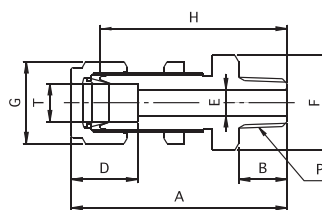

型番 Model No.	適用パイプ外径φ Applicable pipe O.D. T	P (R or NPT)	A	B	D	E	F (HEX)	G (HEX)	H	取付穴径 Panel Hole Size	最大取付板厚 Max. Panel Thickness	質量 (g) Mass
AWEH-3-1	3	1/8	44.9	11	13.4	2.5	14	12	38	8.5	10	29
AWEH-4-1	4	1/8	52.8	11	15.3	3.5	17	14	45.5	11.5	13	45
AWEH-6-1	6	1/8	52.9	11	15.4	5	17	14	45.5	11.5	13	44
AWEH-6-2	6	1/4	54.9	13	15.4	5	17	14	47.5	11.5	13	51
AWEH-8-2	8	1/4	56.8	13	16.8	6	17	15.87	49	13.2	13.5	58
AWEH-10-2	10	1/4	57.8	13	17.8	7	22	19	50	16.2	14.5	83
AWEH-12-3	12	3/8	64.8	14	22.8	9.5	26	23	54	19.5	16	130

※NPTねじタイプは受注生産品になります。
NPT screw type size will be made to order.

AWEP (隔壁メスユニオン)

Bulkhead Female Connector

(unit: mm)

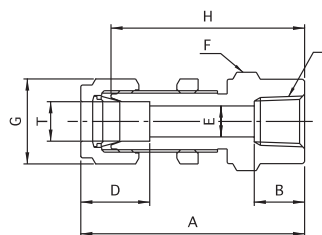

型番 Model No.	適用パイプ外径φ Applicable pipe O.D. T	P (Rc or NPT)	A	B	D	E	F (HEX)	G (HEX)	H	取付穴径 Panel Hole Size	最大取付板厚 Max. Panel Thickness	質量 (g) Mass
AWEP-3-1	3	1/8	47.9	11	13.4	2.5	14	12	41	8.5	10	34
AWEP-4-1	4	1/8	55.3	11	15.3	3.5	17	14	48	11.5	13	58
AWEP-6-1	6	1/8	55.4	11	15.4	5	17	14	48	11.5	13	57
AWEP-6-2	6	1/4	55.4	13	15.4	5	17	14	48	11.5	13	51
AWEP-8-2	8	1/4	56.8	13	16.8	6	17	15.87	49	13.2	13.5	59
AWEP-10-2	10	1/4	57.8	13	17.8	8	22	19	50	16.2	14.5	98
AWEP-12-3	12	3/8	66.8	14	22.8	10	26	23	56	19.5	16	159

※NPTねじタイプは受注生産品になります。
NPT screw type size will be made to order.

ステンレス製締付継手

黄銅製締付継手

PEEK製継手

ステンレス製
カップル

ステンレス製
チェックバルブ

ステンレス製
スピードコントローラー

ステンレス製
ニードルバルブ

ミニチュア
フィットリング

ワンタッチ継手

スピードコントローラー
AQバルブ

AWP (圧力計ユニオン)

Female Connector

(unit:mm)

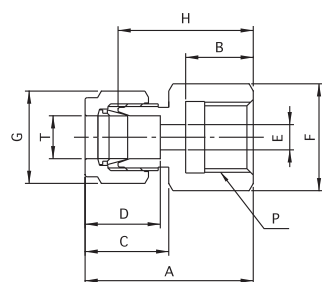

型番 Model No.	適用パイプ外径φ Applicable pipe O.D. T	P G (PF)	A	B	C	D	E	F (HEX)	G (HEX)	H	質量 (g) Mass
AWP-3-1	3	1/8	32.9	12	15.9	13.4	2.5	14	12	26	27
AWP-3-2	3	1/4	35.9	15	15.9	13.4	2.5	17	12	29	35
AWP-4-1	4	1/8	34.8	12	17.8	15.3	3.5	14	14	27.5	32
AWP-4-2	4	1/4	35.8	15	17.8	15.3	3.5	17	14	28.5	36
AWP-6-1	6	1/8	34.9	12	17.9	15.4	5	14	14	27.5	30
AWP-6-2	6	1/4	35.9	15	17.9	15.4	5	17	14	28.5	36
AWP-6-3	6	3/8	37.9	16	17.9	15.4	5	22	14	30.5	55
AWP-6-4	6	1/2	39.9	17	17.9	15.4	5	26	14	32.5	71
AWP-8-2	8	1/4	36.8	15	18.8	16.8	6	17	15.87	29	38
AWP-8-3	8	3/8	38.8	16	18.8	16.8	6	22	15.87	31	34
AWP-8-4	8	1/2	40.8	17	18.8	16.8	6	26	15.87	33	74
AWP-10-2	10	1/4	37.8	15	19.8	17.8	6	17	19	30	48
AWP-10-3	10	3/8	39.8	16	19.8	17.8	6	22	19	32	67
AWP-10-4	10	1/2	41.8	17	19.8	17.8	8	26	19	34	83
AWP-12-2	12	1/4	40.8	15	22.8	22.8	6	22	23	30	89
AWP-12-3	12	3/8	42.8	16	22.8	22.8	6	22	23	32	85
AWP-12-4	12	1/2	44.8	17	22.8	22.8	10	26	23	34	101

※テフロンパッキン付属
Comes with Teflon packing

AWPW (メスユニオン)

Female Connector

(unit:mm)

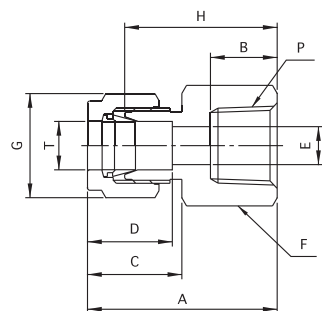

型番 Model No.	適用パイプ外径φ Applicable pipe O.D. T	P (Rc or NPT)	A	B	C	D	E	F (HEX)	G (HEX)	H	質量 (g) Mass
AWPW-3-1	3	1/8	32.9	11	15.9	13.4	2.5	14	12	26	28
AWPW-3-2	3	1/4	33.9	13	15.9	13.4	2.5	17	12	27	35
AWPW-4-1	4	1/8	34.8	11	17.8	15.3	3.5	14	14	27.5	33
AWPW-4-2	4	1/4	35.8	13	17.8	15.3	3.5	17	14	28.5	39
AWPW-6-1	6	1/8	34.9	11	17.9	15.4	5	14	14	27.5	29
AWPW-6-2	6	1/4	35.9	13	17.9	15.4	5	17	14	28.5	44
AWPW-6-3	6	3/8	37.9	14	17.9	15.4	5	22	14	30.5	58
AWPW-6-4	6	1/2	39.9	19	17.9	15.4	5	26	14	32.5	69
AWPW-8-2	8	1/4	36.8	13	18.8	16.8	6	17	15.87	29	43
AWPW-8-3	8	3/8	38.8	14	18.8	16.8	6	22	15.87	31	61
AWPW-8-4	8	1/2	40.8	19	18.8	16.8	6	26	15.87	33	73
AWPW-10-2	10	1/4	37.8	13	19.8	17.8	8	17	19	30	49
AWPW-10-3	10	3/8	39.8	14	19.8	17.8	8	22	19	32	71
AWPW-10-4	10	1/2	41.8	19	19.8	17.8	8	26	19	34	83
AWPW-12-2	12	1/4	40.8	13	22.8	22.8	10	22	23	30	90
AWPW-12-3	12	3/8	42.8	14	22.8	22.8	10	22	23	32	87
AWPW-12-4	12	1/2	44.8	19	22.8	22.8	10	26	23	34	101

※NPTねじタイプは受注生産品になります。
NPT screw type size will be made to order.

AWN (袋ナット)

Cap Nut

(unit:mm)

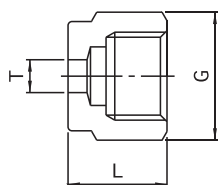

型番 Model No.	適用パイプ外径φ Applicable pipe O.D. T	G (HEX)	L	質量 (g) Mass
AWN-3	3	12	12	9
AWN-4	4	14	12.5	10
AWN-6	6	14	12.5	9
AWN-8	8	15.87	13.5	13
AWN-10	10	19	15	18
AWN-12	12	23	17.5	30

AWFF (フェルール) フロント

Front Ferrule

(unit:mm)

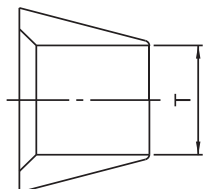

型番 Model No.	適用パイプ外径φ Applicable pipe O.D. T	質量 (g) Mass
AWFF-3	3	0.4
AWFF-4	4	0.5
AWFF-6	6	0.7
AWFF-8	8	0.9
AWFF-10	10	1.1
AWFF-12	12	3.0

AWFR (フェルール) リア

Rear Ferrule

(unit:mm)

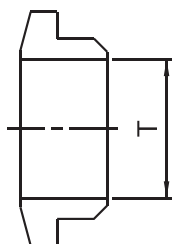

型番 Model No.	適用パイプ外径φ Applicable pipe O.D. T	質量 (g) Mass
AWFR-3	3	0.2
AWFR-4	4	0.3
AWFR-6	6	0.4
AWFR-8	8	0.5
AWFR-10	10	0.6
AWFR-12	12	1.2

AWI (インサートリング)

Insert Ring

(unit:mm)

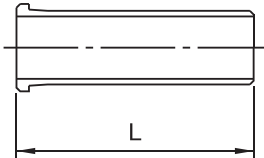

型番 Model No.	適用チューブ 外径×内径 Applicable tube O.D.×I.D.	L	適用チューブ Applicable tube	質量 (g) Mass
AWI-AF04	4×2.5	18	AX-1204、F-1504	0.5
AWI-T04	4×2	18	FE-04	0.3
AWI-AFT06	6×4	18	AX-1206、F-1506、FE-06	0.6
AWI-A08	8×6	19	AX-1208、F-1508	1.2
AWI-T08	8×6	19	FE-08	1.3
AWI-A10	10×7.5	20	AX-1210、F-1510	1.9
AWI-T10	10×8	20	FE-10	2.5
AWI-A12	12×9.2	25	AX-1212	2.4
AWI-A12-9	12×9	25	AX-1212-9、F-1512	2.3
AWI-T12	12×10	25	FE-12	5.1

W-INTERLOCK JOINTにプラスチックチューブを接続する際に、ご使用ください。

材質:SUS316

Please use when connecting plastic tube.
Material:SUS316

※注意事項
プラスチックチューブ使用時の締付け回転数
φ4~φ12……1¼~1½回転
取外し後の再締付け……½~¼回転

※Note:
When using plastic tube, please tighten as below:
φ4~φ12……1¼~1½turns
(450~540 degrees)
When reconnecting the plastic tube, please tighten ½~¼turn (45~90 degrees)

AX : アミドフレックス
F : スーパーフレックス
FE : ふっ素樹脂チューブ
AX : AMIDFLEX
F : SUPERFLEX
FE : Fluorine Resin Tube

DAW-00-SUS (PTパネル)

PT Panel (Stainless Steel)

(unit:mm)

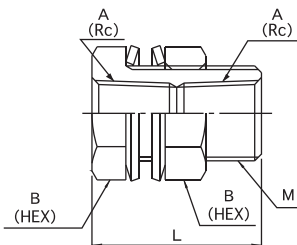

型番 Model No.	L	A (Rc)	B (HEX)	M	取付穴径 Panel Hole Size	最大取付板厚 Max. Panel Thickness	質量 (g) Mass
DAW-01-SUS	25	1/8	17	M14×1.0	15	12	27
DAW-02-SUS	25	1/4	21	M18×1.5	19	11.5	38
DAW-03-SUS	30	3/8	26	M22×1.5	23	15.5	65
DAW-04-SUS	35	1/2	30	M27×1.5	28	20	95

ミニチュアバルブシリーズ

Miniature Valve Series

■ ミニチュアバルブ使用条件 Miniature Valve Use Condition

- 使用温度：100℃以下
Working temperature：~100℃
- 使用圧力：2.0MPa以下
Working pressure range：~2.0MPa

■ 構造断面図 Internal Structure

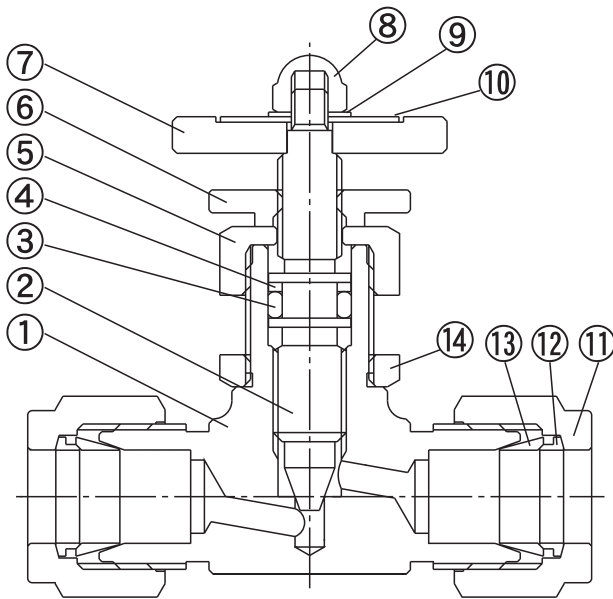

No.	名称 Part Name	材質 Material
①	本体 Body	SUS316
②	スピンドル Spindle	SUS316
③	Oリング O Ring	VITON
④	バックアップリング Back Up Ring	PTFE
⑤	グランドナット Grand Nut	SUS304
⑥	ロックナット Lock Nut	C3604BD(NiIII)
⑦	ハンドル Handle	C3604BD(NiIII)
⑧	六角袋ナット Domed Cap Nut	SUS304
⑨	歯付座金 Toothed Lock Washer	SUS304
⑩	銘板 Nameplate	A5052P
⑪	袋ナット Cap Nut	SUS316
⑫	フェルール(リア) Rear Ferrule	SUS316
⑬	フェルール(フロント) Front Ferrule	SUS316
⑭	マウントナット Mount Nut	SUS304

AWVH (ミニチュアバルブ) H型

Miniature Valve (H-Type)

(unit:mm)

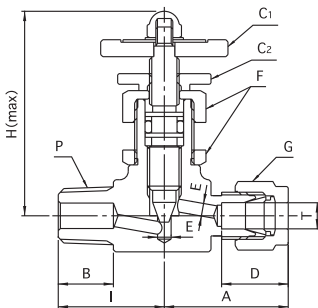

型番 Model No.	適用パイプ 外径φ Applicable pipe O.D. T	P R (PT)	A	B	C ₁ (φ)	C ₂ (φ)	D	E	F (HEX)	G (HEX)	H	I	取付穴径 Panel Hole Size	質量 (g) Mass
AWVH-4-1	4	1/8	28.8	11	30	22	15.3	2.6	17	14	51	22	14.5	125
AWVH-6-2	6	1/4	28.9	13	30	22	15.4	3	17	14	51	25	14.5	127
AWVH-8-2	8	1/4	29.8	13	30	22	16.8	3	17	15.87	51	25	14.5	133
AWVH-10-2	10	1/4	30.8	13	30	22	17.8	3	17	19	51	25	14.5	141



ステンレス製締付継手

黄銅製締付継手

PEEK製継手

ステンレス製
カップル

ステンレス製
チェックバルブ

ステンレス製
スピードコントローラー

ステンレス製
ニードルバルブ

ミニチュア
フィッティング

ワンタッチ継手

スピードコントローラー
AQバルブ

AWVS (ミニチュアバルブ) S型

Miniature Valve (S-Type)

(unit:mm)

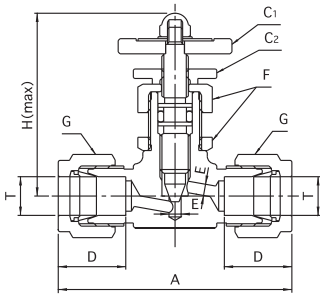

型番 Model No.	適用パイプ 外径φ T	A	C ₁ (φ)	C ₂ (φ)	D	E	F (HEX)	G (HEX)	H	取付穴径 Panel Hole Size	質量 (g) Mass
AWVS-4-0	4	57.6	30	22	15.3	2.6	17	14	51	14.5	138
AWVS-6-0	6	57.8	30	22	15.4	3	17	14	51	14.5	132
AWVS-8-0	8	59.6	30	22	16.8	3	17	15.87	51	14.5	140
AWVS-10-0	10	61.6	30	22	17.8	3	17	19	51	14.5	158



AWVD (ミニチュアバルブ) D型

Miniature Valve (D-Type)

(unit:mm)

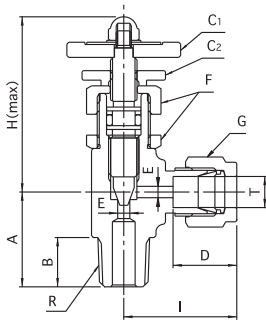

型番 Model No.	適用パイプ 外径φ T	R (PT)	A	B	C ₁ (φ)	C ₂ (φ)	D	E	F (HEX)	G (HEX)	H	I	取付穴径 Panel Hole Size	質量 (g) Mass
AWVD-4-1	4	1/8	23	11	30	22	15.3	3	17	14	50	29.3	14.5	124
AWVD-6-2	6	1/4	25	13	30	22	15.4	3	17	14	50	29.4	14.5	128
AWVD-8-2	8	1/4	25	13	30	22	16.8	3	17	15.87	50	29.8	14.5	130
AWVD-10-2	10	1/4	25	13	30	22	17.8	3	17	19	50	30.8	14.5	141



AWVL (ミニチュアバルブ) L型

Miniature Valve (L-Type)

(unit:mm)

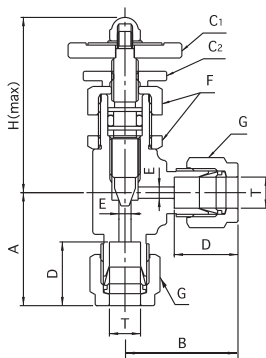

型番 Model No.	適用パイプ 外径φ T	A	B	C ₁ (φ)	C ₂ (φ)	D	E	F (HEX)	G (HEX)	H	取付穴径 Panel Hole Size	質量 (g) Mass
AWVL-4-0	4	29.3	29.3	30	22	15.3	3	17	14	50	14.5	134
AWVL-6-0	6	29.4	29.4	30	22	15.4	3	17	14	50	14.5	105
AWVL-8-0	8	29.8	29.8	30	22	16.8	3	17	15.87	50	14.5	136
AWVL-10-0	10	30.8	30.8	30	22	17.8	3	17	19	50	14.5	158



技術資料 AW W-インターロック式締付継手(ステンレス製)

STAINLESS W-INTERLOCK JOINT AW FITTINGS Technical data

■ 試料 Samples

- 継手 …… ハーフユニオン φ3、φ4、φ6、φ8、φ10、φ12の各サイズ
Fittings …… Each size for male connectors : φ3, φ4, φ6, φ8, φ10, φ12
- パイプ …… SUS316TP
Pipe …… SUS316TP

■ 繰り返し結合耐圧試験 Cyclic Coupling Pressure Test

A 試験方法 Test method

- ・パイプを継手に正しくセットし、基準締め付けで(P43参照)締め付けた後分解し、再び組み立て作業を8回繰り返し、各回ごとに41MPaの圧力を加え5分間保持した時の漏れの有無を確認する。
Inserting the pipe into the fitting correctly, we tightened the fitting nut in a basic way (Please refer to the page, 43) and then disassembled the parts. Assembling and disassembling them for eight times over again, check there is no leakage at each time for the joint part which is pressurized at 41MPa for five minutes.
 - ・又、8回終了後、ヘリウムリーク試験に於いて漏れの有無を確認する。
Finishing the operation above for eight times, check there is no leakage at the helium leak test.
 - ・以上の試験に合格したら、82MPaの圧力を加え5分間保持した時の漏れの有無を確認する。
The fitting having passed the test above, check there is no leakage for the joint part which is pressurized at 82MPa for five minutes.
 - ・又、その後のヘリウムリーク試験に於いて漏れの有無を確認する。
Check there is no leakage at the helium leak test afterwards.
- ※分解は各回ごとにパイプを継手本体から取り外し、各回ごとの組み立て時の増し締めは、0~1/16回転程度行なった。
※Removed the pipe from the fitting body at each time when disassembling. Retightened the nut from 0 to 1/16th around at each assembling.

B-1 41MPa加圧時の漏れ試験結果 Leak test results at 41MPa

パイプサイズ Pipe Size	パイプ肉厚(mm) Wall thickness		
	t = 1	t = 1.5	t = 2
φ3	各回時とも異常なし Nothing particular at each time	—	—
φ4	各回時とも異常なし Nothing particular at each time	—	—
φ6	各回時とも異常なし Nothing particular at each time	—	—
φ8	各回時とも異常なし Nothing particular at each time	—	—
φ10	各回時とも異常なし Nothing particular at each time	—	—
φ12	各回時とも異常なし Nothing particular at each time	—	—

B-2 8回時終了後のヘリウムリーク試験結果 Helium leak test results after the operation for eight times

(unit: Torr·ℓ/sec)

パイプサイズ Pipe Size	パイプ肉厚(mm) Wall thickness		
	t = 1	t = 1.5	t = 2
φ3	4.9×10 ⁻¹¹ に於いて漏れなし No leakage at 4.9×10 ⁻¹¹	—	—
φ4	4.9×10 ⁻¹¹ に於いて漏れなし No leakage at 4.9×10 ⁻¹¹	—	—
φ6	4.9×10 ⁻¹¹ に於いて漏れなし No leakage at 4.9×10 ⁻¹¹	—	—
φ8	4.9×10 ⁻¹¹ に於いて漏れなし No leakage at 4.9×10 ⁻¹¹	—	—
φ10	4.9×10 ⁻¹¹ に於いて漏れなし No leakage at 4.9×10 ⁻¹¹	—	—
φ12	4.9×10 ⁻¹¹ に於いて漏れなし No leakage at 4.9×10 ⁻¹¹	—	—

B-3 82MPa加圧時の漏れ試験結果 Leak test results at 82MPa

パイプサイズ Pipe Size	パイプ肉厚(mm) Wall thickness		
	t = 1	t = 1.5	t = 2
φ3	異常なし Nothing particular at each time	—	—
φ4	異常なし Nothing particular at each time	—	—
φ6	異常なし Nothing particular at each time	—	—
φ8	異常なし Nothing particular at each time	—	—
φ10	異常なし Nothing particular at each time	—	—
φ12	パイプがバースト Pipe burst	異常なし Nothing particular at each time	—

B-4 82MPa加圧後のヘリウムリーク試験結果 Helium leak test results at 82MPa

(unit:Torr・ℓ/sec)

パイプサイズ Pipe Size	パイプ肉厚(mm) Wall thickness		
	t = 1	t = 1.5	t = 2
φ3	4.9×10 ⁻¹¹ に於いて漏れなし No leakage at 4.9×10 ⁻¹¹	—	—
φ4	4.9×10 ⁻¹¹ に於いて漏れなし No leakage at 4.9×10 ⁻¹¹	—	—
φ6	4.9×10 ⁻¹¹ に於いて漏れなし No leakage at 4.9×10 ⁻¹¹	—	—
φ8	4.9×10 ⁻¹¹ に於いて漏れなし No leakage at 4.9×10 ⁻¹¹	—	—
φ10	4.9×10 ⁻¹¹ に於いて漏れなし No leakage at 4.9×10 ⁻¹¹	—	—
φ12	4.9×10 ⁻¹¹ に於いて漏れなし No leakage at 4.9×10 ⁻¹¹		

■ 繰り返し結合リーク試験 Cyclic Coupling Leak Test

A 試験方法 Test method

- パイプを継手に正しくセットし、基準締め付けで(P43参照)締め付けた後分解し、再び組み立ての作業を3~10回繰り返し、各3回、6回、10回時にヘリウムリーク試験に於いて漏れの有無を確認する。

Inserting the pipe into the fitting correctly, we tightened the fitting nut in a basic way (Please refer to the page,43) and then disassembled the parts. Assembling and disassembling them from three to ten times over again, check there is no leakage at the helium leak test at the third, the sixth and the tenth time each.

※分解は各回ごとパイプを継手本体から取り外し、各回ごとの組み立て時の増し締めは、0~1/16回転程度行なった。

※Removed the pipe from the fitting body at each time when disassembling. Retightened the nut from 0 to 1/16th around at each assembling.

B-1 3回時のヘリウムリーク試験結果 Helium leak test results after the operation for three times

(unit:Torr・ℓ/sec)

パイプサイズ Pipe Size	パイプ肉厚(mm) Wall thickness		
	t = 1	t = 1.5	t = 2
φ3	2.9×10 ⁻¹¹ に於いて漏れなし No leakage at 2.9×10 ⁻¹¹	—	—
φ4	2.9×10 ⁻¹¹ に於いて漏れなし No leakage at 2.9×10 ⁻¹¹	—	—
φ6	2.9×10 ⁻¹¹ に於いて漏れなし No leakage at 2.9×10 ⁻¹¹	—	—
φ8	2.9×10 ⁻¹¹ に於いて漏れなし No leakage at 2.9×10 ⁻¹¹	—	—
φ10	2.9×10 ⁻¹¹ に於いて漏れなし No leakage at 2.9×10 ⁻¹¹	—	—
φ12	2.9×10 ⁻¹¹ に於いて漏れなし No leakage at 2.9×10 ⁻¹¹		

B-2 6回時のヘリウムリーク試験結果 Helium leak test results after the operation for six times

(unit:Torr・ℓ/sec)

パイプサイズ Pipe Size	パイプ肉厚(mm) Wall thickness		
	t = 1	t = 1.5	t = 2
φ3	2.9×10 ⁻¹¹ に於いて漏れなし No leakage at 2.9×10 ⁻¹¹	—	—
φ4	2.9×10 ⁻¹¹ に於いて漏れなし No leakage at 2.9×10 ⁻¹¹	—	—
φ6	2.9×10 ⁻¹¹ に於いて漏れなし No leakage at 2.9×10 ⁻¹¹	—	—
φ8	2.9×10 ⁻¹¹ に於いて漏れなし No leakage at 2.9×10 ⁻¹¹	—	—
φ10	2.9×10 ⁻¹¹ に於いて漏れなし No leakage at 2.9×10 ⁻¹¹	—	—
φ12	2.9×10 ⁻¹¹ に於いて漏れなし No leakage at 2.9×10 ⁻¹¹		

B-3 10回時のヘリウムリーク試験結果 Helium leak test results after the operation for ten times

(unit:Torr・ℓ/sec)

パイプサイズ Pipe Size	パイプ肉厚(mm) Wall thickness		
	t = 1	t = 1.5	t = 2
φ3	2.9×10 ⁻¹¹ に於いて漏れなし No leakage at 2.9×10 ⁻¹¹	—	—
φ4	2.9×10 ⁻¹¹ に於いて漏れなし No leakage at 2.9×10 ⁻¹¹	—	—
φ6	2.9×10 ⁻¹¹ に於いて漏れなし No leakage at 2.9×10 ⁻¹¹	—	—
φ8	2.9×10 ⁻¹¹ に於いて漏れなし No leakage at 2.9×10 ⁻¹¹	—	—
φ10	2.9×10 ⁻¹¹ に於いて漏れなし No leakage at 2.9×10 ⁻¹¹	—	—
φ12	2.9×10 ⁻¹¹ に於いて漏れなし No leakage at 2.9×10 ⁻¹¹		

■ 引張り試験 Tensile Test

A 試験方法 Test method

- 継手を基準締め付け回転数(P43参照)にて組み立て、その後引張り試験機にて引張りを加えて破壊状態を確認する。
Installing the fitting with the tensile device, being the nut tightened in a basic way (Please refer to the page, 43) check the destruction condition by pulling the tube as the figure shows on the right.

B 試験結果 Test results

(unit:N)

パイプサイズ Pipe Size	パイプ種類 Pipe type	
	引張り強度平均値 Tensile strength average	状況 Situation
φ3	2700	全てパイプ離脱 All pipes removed
φ4	3800	全てパイプ離脱 All pipes removed
φ6	6300	全てパイプ離脱 All pipes removed
φ8	6600	全てパイプ離脱 All pipes removed
φ10	10200	全てパイプ離脱 All pipes removed
φ12	12000	全てパイプ離脱 All pipes removed

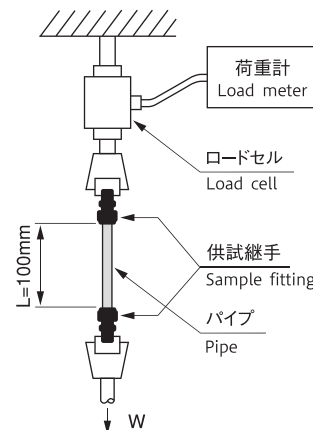

- 試験機「最大測定2ton」
Testing equipment "Maximum measurement up to 2tons"
- 各試料とも全て基準数値をクリアした。
Each sample satisfied the reference value.

■ 破壊圧試験 Bursting Pressure Test

A 試験方法 Test method

- 繰り返し結合耐圧試験に合格した継手に破壊圧を加え、継手部の異常の有無を確認するとともに破壊圧値を測定する。
Applying the bursting pressure to the fitting which passed the cyclic coupling pressure test, check there is nothing wrong for the joint part and measure the bursting pressure value for it.

B 試験結果 Test results

(unit:MPa)

パイプサイズ Pipe Size	破壊圧平均値 Bursting pressure value	状況 Situation
φ3	370	パイプがバースト pipe burst
φ4	280	パイプがバースト pipe burst
φ6	179	パイプがバースト pipe burst
φ8	132	パイプがバースト pipe burst
φ10	96	パイプがバースト pipe burst
φ12	84	パイプがバースト pipe burst

(unit:mm)

パイプ外径 Pipe O.D.	φ3	φ4	φ6	φ8	φ10	φ12
パイプの肉厚 Wall thickness	1	1	1	1	1	1

- 全てのパイプがバーストし継手部に漏れ、抜け等の異常は確認されなかった。
All pipes having been burst, nothing particularly could be seen such as the leakage or pipes pulled out for the joint part.

■ 耐衝撃圧試験 Shock Resistant Test

A 試験方法 Test method

- インパルステスターにて衝撃圧定格圧力20.6MPaの150^{±7}%とし、周波数は30～75サイクル/minとする。
Applying the rated pressure 20.6MPa (150±7%) to the fittings with an impulse tester and the cyclic frequency for it from 30 to 75/min.
- 20万衝撃サイクル試験を行ない、漏れ及び継手部破損の有無を調べる。
Check there is no leakage or breakage for the joint part after we perform the cyclic shock test for it at 200,000 times.

※使用パイプは繰り返し結合試験と同一サイズとする。
The pipe is the same size as the one used for the cyclic tests above.

B 試験結果 Test results

- 各試料とも、いずれも異常は認められなかった。
Nothing particularly could be seen for each sample.

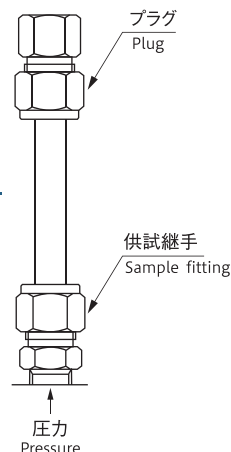

■ 耐振動試験 Vibration Resistance Test

A 試験方法 Test method

- 下図のように、組み立てた継手の固定端に曲げ応力が生じるような繰り返し荷重を1,400サイクル/min以上の割合で加え、同時に定格圧力(20.6MPa)を加えて、1,000万回振動サイクル後に漏れ及び継手部の破損の有無を調べる。

As the figure shows below, we applied the cyclic pressure to one end of the pipe which might bend at more than 1400 cycles/min. and pressurized it inside at 20.6MPa at the same time. And check there is no leakage or breakage for the joint part after we vibrate the parts at 10,000,000 times.

※曲げ応力はφ3～φ12まで98N/mm²とする。
The bending stress φ3 to φ12 : 98N/mm²

※使用パイプは繰り返し結合試験と同一サイズとする。
The pipe is the same size as the one used for the cyclic tests above.

長さ(L)と変位(δ)との計算式

Formula between length and displacement

$$L = \sqrt{\frac{3\delta Ee}{\sigma}}$$

E : パイプ材料の縦弾性係数 (2.1×10⁵N/mm²)
 Young's modulus for pipe material (2.1×10⁵N/mm²)
 e : パイプ外径の1/2 (mm)
 Pipe outside diameter (1/2(mm))
 σ : 曲げ応力 (N/mm²)
 Bending stress (N/mm²)

B 試験結果 Test results

- 各試料とも、いずれも異常は認められなかった。
Nothing particularly could be seen for each sample.

